

High Pressure Flow Divider

420 bar, 250 l/min
Series MTDA..HD

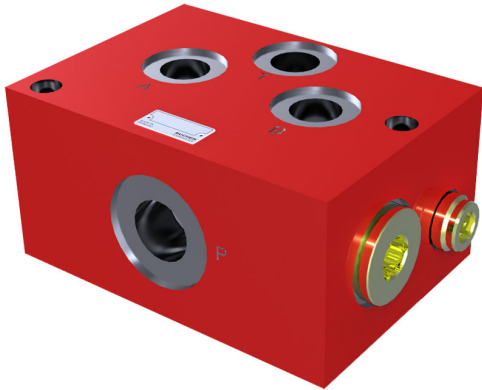

- these valves do not require maintenance.
- flows can be split or merged with accuracy (divide/combine functions).
- Functions:
 - decompression orifice
 - make-up valves
 - Crossline relief valve

1 Description

Series MTDA..HD units are flow dividing valves that operate automatically. They are intended for use with hydraulic fluids. They divide a flow into two parts. When flow passes through a valve in the opposite direction, the two part-flows are combined into one single flow (added). The dividing and combining functions are largely independent of the pressures of the two divided flows and of the fluid viscosity.

In order for the valve to work properly, a continuous flow is required at all ports. For example, if one actuator is no longer able to move, then the other part-flow will also be restricted. If the two actuators served by the flow divider operate at different pressures, then the pressure of the total flow entering the valve will correspond to the higher of the two actuator pressures.

2 Symbols

Standard Function "H"

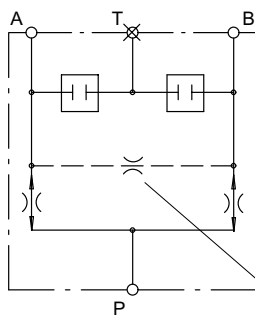

Function "N" with anti-cavitation check valve

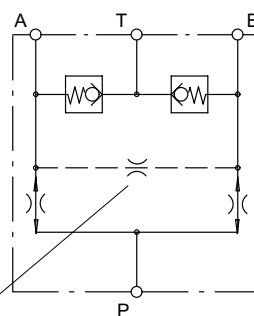

Funktion "P" with crossline relief valve

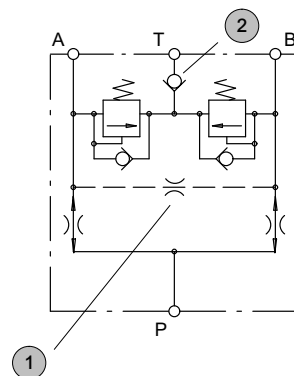

1 Decompression orifice (This option must be commanded in a separated text, see 6)

2 Check valves in T (only in connection with "P")

3 Technical data

General characteristics	Unit	Description, value
Maximum operating pressure	bar	420
Oil temperature range	°C	-20 ... +80
Viscosity range	mm ² /s	10 ... 300
Maximum admissible level of contamination of the hydraulic fluid		ISO 4406 class 20/18/15 (NAS 1638 class 9), achievable with a filter rating of $\beta_{10} \geq 75$
Nitrile seals		NBR

4 Characteristic curves

4.1 Pressure drop characteristics

Pressure drop v. flow rate with oil viscosity of 35 mm²/s
(Q_{Zu} 100% = Q_{Nenn})

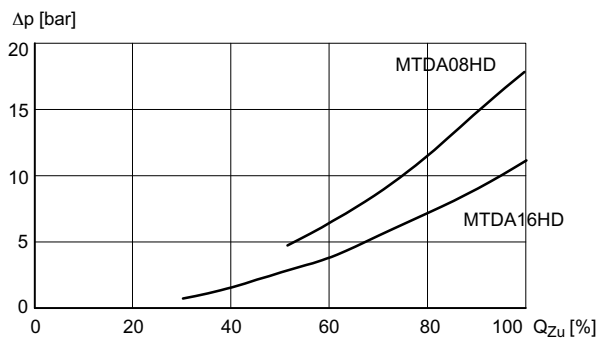

4.2 Division accuracy

(without Decompression orifice)

Division error v. flow rate with oil viscosity of 35 mm²/s
(Q_{Zu} 100% = Q_{Nenn})

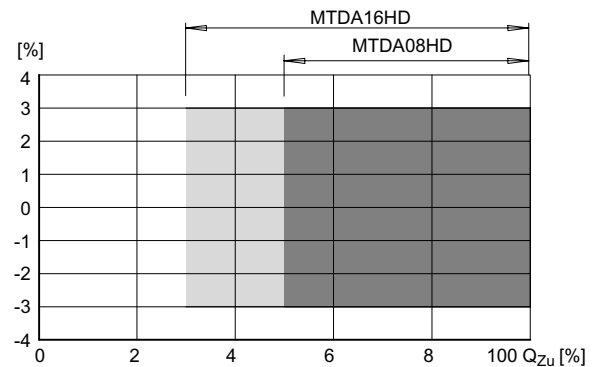

IMPORTANT : Division accuracy $\pm 3\%$ of the maximal flow rate, based on nominal volume flow range of the respective flow divider (see example abs. 6.1). For higher division accuracy contact Bucher Hydraulics.

4.2.1 Anti-shock valve

Q [l/min] = flow rate from actuator to tank
Δp [bar] = pressure difference from actuator to tank

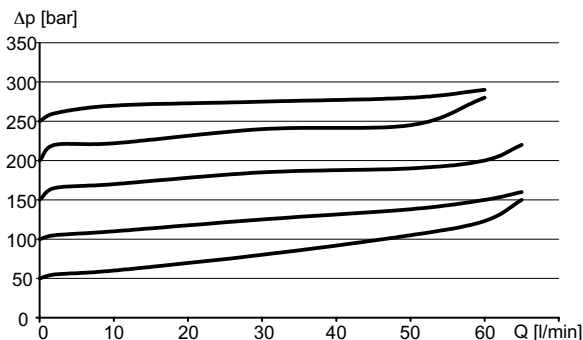

For flow rates < 60 l/min contact Bucher Hydraulics

4.2.2 Make-up valve

Q [l/min] = flow rate from tank to actuator
Δp [bar] = pressure difference from tank to actuator

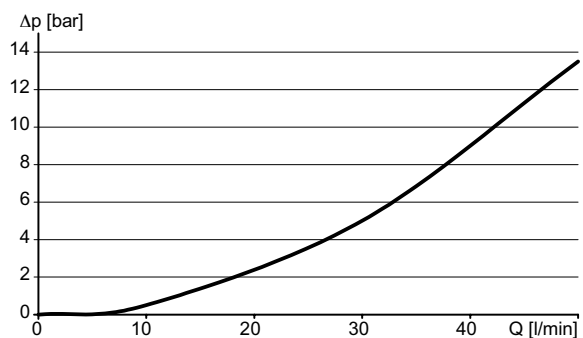

5 Dimensions

5.1 MTD A08HD

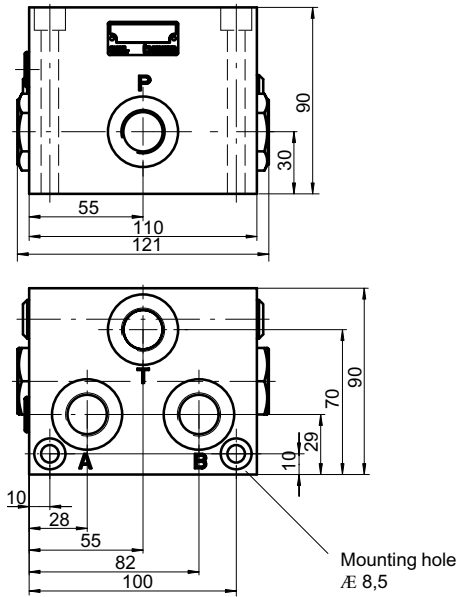

5.2 MTD A16HD

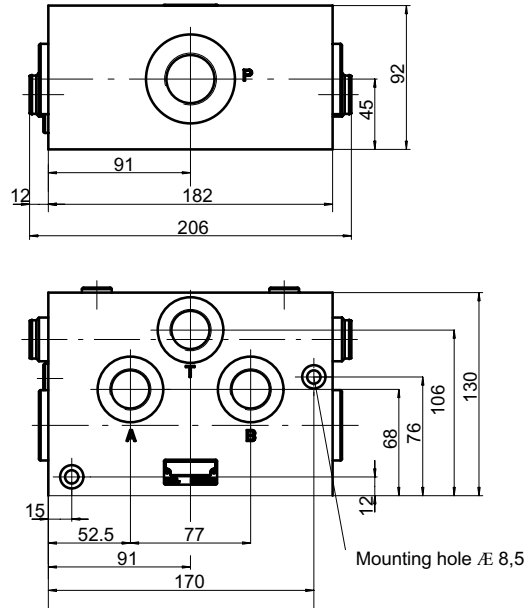

6 Ordering code

M T D A [] H D - [] G [] - [] P=² D=³

Flow divider

Bi-directional

Threaded ports

Nominal size 08 or 16

High pressure

Flow range inlet flow (l/min):

NG 08		NG 16	
004 = 2-4	025 = 12-25	100 = 35-100	
006 = 3-6	032 = 16-32	120 = 40-120	
008 = 4-8	050 = 25-50	160 = 50-160	
012 = 6-12	075 = 37-75	200 = 60-200	
016 = 8-16	100 = 50-100	250 = 75-250	

Port threads

Size 08: G 1/2" = G 12
Size 16: A,B,T = G 3/4" / P = G 1" = G 34

Options Check valve in the T line = R¹
without = *

Functions Standard = H
with make-up check valve = N
with crossline relief valve = P²

1) Only in connection with "P" possible

2) Pressure settings in bar available for the anti-shock valve (measured at 10 l/min test flow) 25, 32, 40, 50, 63, 80, 100, 125, 140, 160, 175, 190, 210, 230, 250, 280, 300, 330, 350, 380 (for other pressures, consult BUCHER)

3) State the diameter of the balancing orifice, if required (e.g. E 0.6 - D = 06)

6.1 Example for division accuracy

Flow range: To 60 l/min, required division of $Q_A/Q_B = 30$ l/min (division 1 : 1)

Flow divider: **MTDA08-075G12*-P**
flow range 37...75 l/min
max. flow rate 75 l/min

max. allowable deviation = $75 \text{ l/min} \times \pm 3\% = \pm 2,25 \text{ l/min}$

Resulting part- flow rate at Q_{Zu} 60 l/min:
Port A - $Q_{min} = 27,75 \text{ l/min} / Q_{max} = 32,25$
Port B - $Q_{min} = 27,75 \text{ l/min} / Q_{max} = 32,25$

7 Installation attitude and mounting

To prevent the weight of the spool causing division inaccuracies, the valve must be installed so that the spool axis is horizontal. When mounting the valve, make sure that the body is not subjected to any distorting forces. Do not use tapered-thread pipe fittings.

8 Example of use

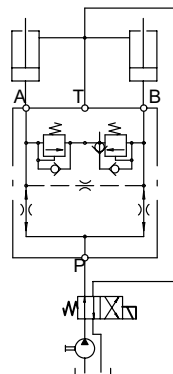

9 Fluid

MTDA..HD flow divider require fluid with a minimum cleanliness level of NAS 1638, Class 9 or ISO 4406, code 20/18/15.

HLP hydraulic oils to DIN 51524, Part 2, can be used without any special restriction as long as they remain within the specified temperature and viscosity ranges. HFC fire-resistant fluids to DIN 51502 can be used. Note that all fire-resistant fluids require special versions of the valves and must be approved by Bucher Hydraulics. We recommend the use of fluids that contain anti-wear additives for mixed-friction operating conditions. Fluids without appropriate additives can reduce the service life of pumps and motors. The user is responsible for maintaining, and regularly checking, the fluid quality. Bucher Hydraulics recommends a load capacity of $\geq 30 \text{ N/mm}^2$ to Bruggen DIN 51347-2.

10 Fluid cleanliness class

Cleanliness class (RK) onto ISO 4406 and NAS 1638

Code ISO 4406	Number of particles / 100 ml			
	$\leq 4 \mu\text{m}$	$\leq 6 \mu\text{m}$	$\leq 14 \mu\text{m}$	NAS 1638
23/21/18	800000	200000	250000	12
22/20/18	400000	100000	250000	-
22/20/17	400000	100000	130000	11
22/20/16	400000	100000	64000	-
21/19/16	200000	50000	64000	10
20/18/15	100000	25000	32000	9
19/17/14	50000	13000	16000	8
18/16/13	25000	6400	8000	7
17/15/12	13000	3200	4000	6
16/14/12	6400	1600	4000	-
16/14/11	6400	1600	2000	5
15/13/10	3200	800	1000	4
14/12/9	1600	400	500	3
13/11/8	800	200	250	2