

SUBPLATE TYPE ES8A114LL
GRUNDPLATTE TYP ES8A114LL

Sub plate CETOP 8 with A – B on side = 1.1/4”G

P – T on side = 1.1/4”G. Drain and pilot = 1/4”G. Weight = 27 Kg

Grundplatte CETOP 8 mit A – B seitlich = 1.1/4”G

P – T seitlich = 1.1/4”G. Leckoel und Steueranschlusse 1/4”G. Gewicht = 27 Kg

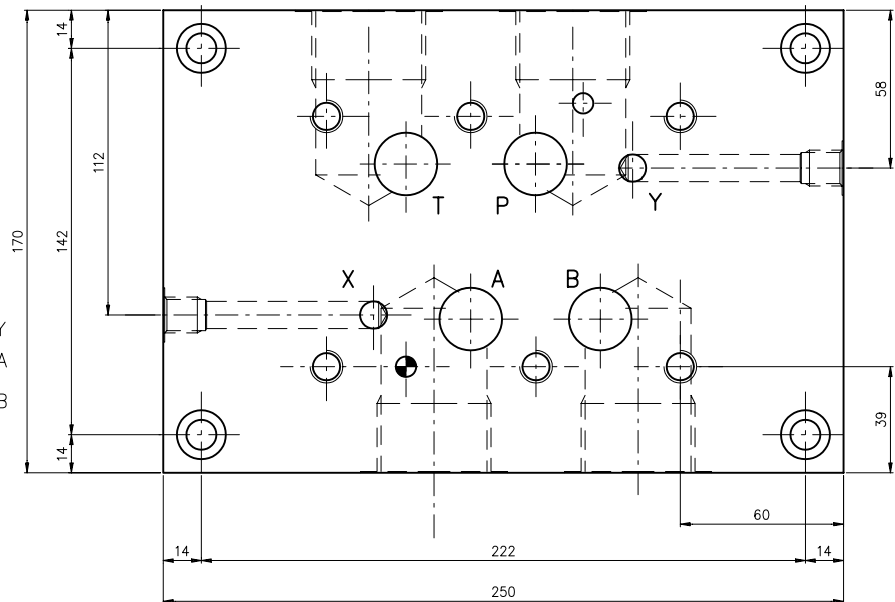
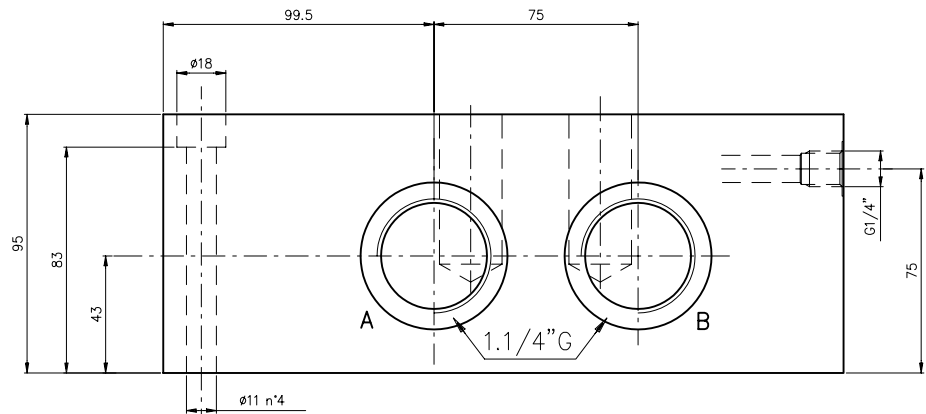

hydraulic symbol
 Symbol

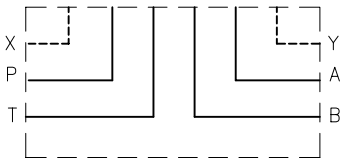

Ordering code
 Bestell-Code:

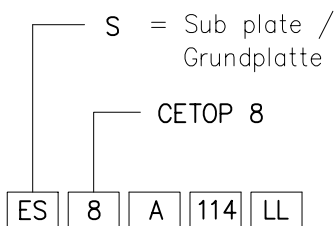

LL = Side ports – seitlich Anschlusse
 114 = 1.1/4”G
 A = Model / Modell

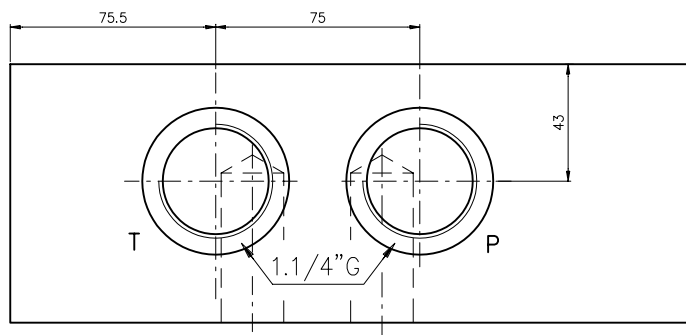

CETOP 8
NG 25

