

U 0.25 R - U 0.5 R

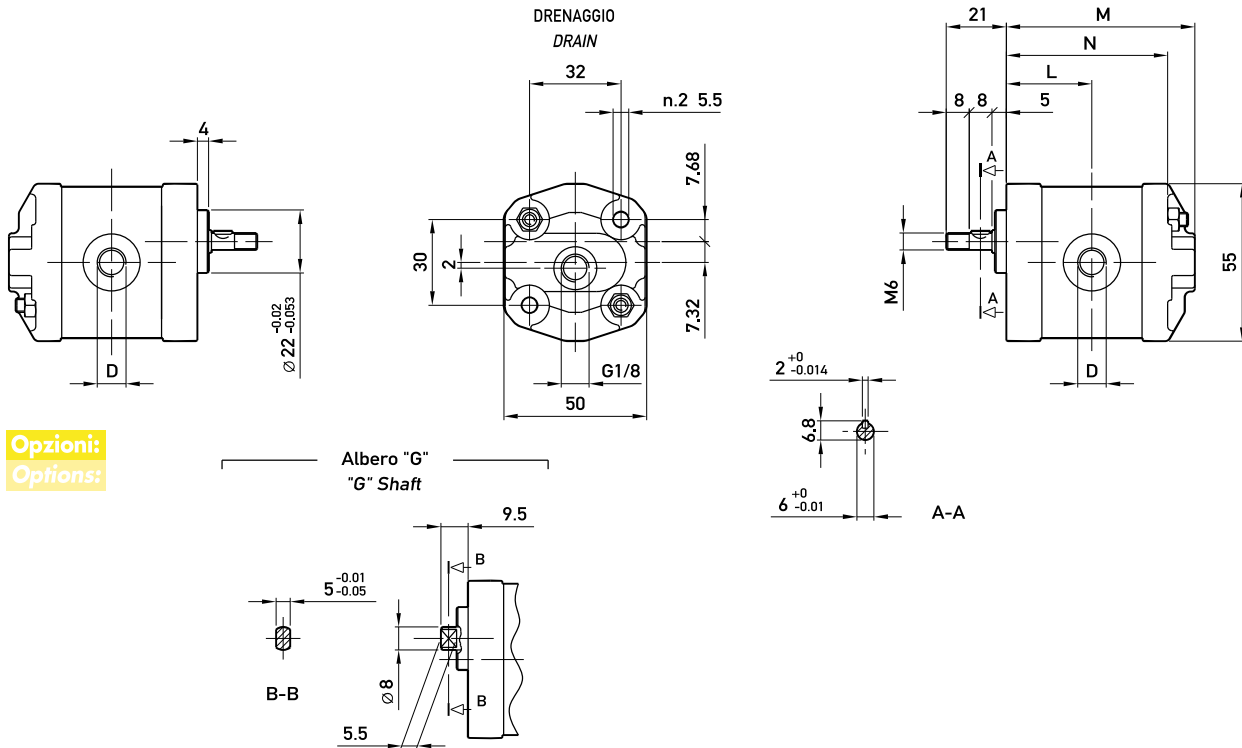

Filetti M10x1 profondità utile 9 mm.
 Filetti G1/4 profondità utile 9 mm.
 Porta di drenaggio (copercchio): filetto G1/8
 profondità utile 8 mm.
 Fissaggio pompa: n. 2 viti M5,
 coppia di serraggio 5,4 ± 0,5 Nm.

M10x1 threads depth 9 mm.
 G1/4 threads depth 9 mm.
 Drain port (cover): G1/8 thread depth 8 mm.
 To mount the pump: n. 2 M5 screws, with a
 torque wrench setting fixed at 5.4 ± 0.5 Nm.



TIPO TYPE	CILINDRATA DISPLACEMENT	PORTATA a 1500 giri/min FLOW at 1500 rev/min	PRESSIONI MASSIME MAX PRESSURE			VELOCITÀ MASSIMA MAX SPEED	DIMENSIONI DIMENSIONS			
			P ₁	P ₂	P ₃		M	N	L	D
	cm ³ /giro (cm ³ /rev)	litri/min (litres/min)	bar	bar	bar	giri/min (rpm)	mm	mm	mm	-
U 0.25 R 18	0,19	0,29	150	170	190	7000	54	44,5	24	M10x1
U 0.25 R 24	0,26	0,38	150	170	190	7000	55	45,5	24,5	M10x1
U 0.25 R 30	0,32	0,48	150	170	190	7000	56	46,5	25	M10x1
U 0.25 R 36	0,38	0,58	150	170	190	7000	57	47,5	25,5	M10x1
U 0.25 R 48	0,51	0,77	150	170	190	7000	59	49,5	26,5	M10x1
U 0.25 R 60	0,64	0,96	150	170	190	7000	61	51,5	27,5	M10x1
U 0.5 R 0,50	0,50	0,75	150	170	190	7000	63	53,5	28,5	G1/4
U 0.5 R 0,75	0,63	0,94	150	170	190	7000	64	54,5	29	G1/4
U 0.5 R 1,00	0,88	1,31	150	170	190	7000	66	56,5	30	G1/4
U 0.5 R 1,30	1,00	1,50	150	170	190	6000	67	57,5	30,5	G1/4
U 0.5 R 1,60	1,25	1,88	150	170	190	5000	69	59,5	31,5	G1/4
U 0.5 R 2,00	1,50	2,25	150	170	190	4000	71	61,5	32,5	G1/4