

A-WB-C-SE-...-L-...-...

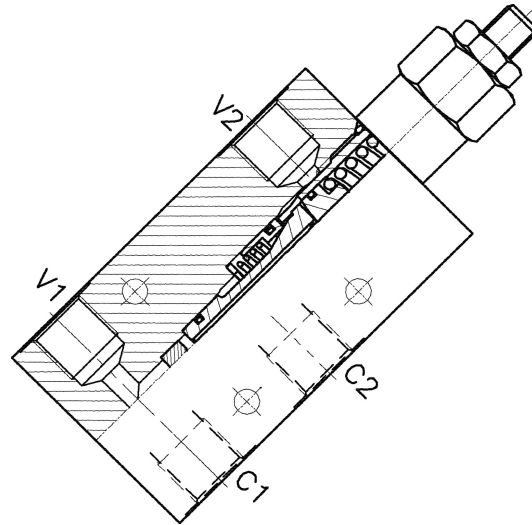
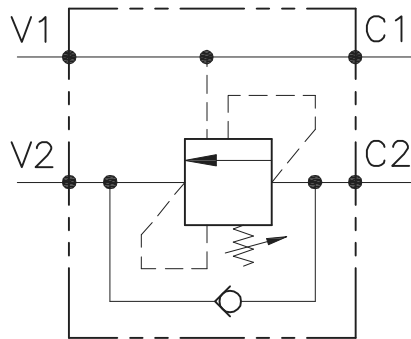

CARATTERISTICHE

Luce nominale	DN 8/10
Portata min/max	1/60 l/min - 0.26/15.9 GPM
Pressione max. di picco	450 bar - 6525 PSI
Pressione max. di taratura	350 bar - 5075 PSI
Rapporto di pilotaggio standard	Vedi tab. / See tab.
Temperatura ambiente	-30°C + 50°C
Temperatura olio	-30°C + 80°C
Filtraggio consigliato	30 micron

PERFORMANCE

Rated size
Min/max flow-rate
Max peak pressure
Max setting pressure
Standard pilot ratio
Room temperature
Oil temperature
Recommended filtration

NOTE:

La taratura deve essere 1.3 volte maggiore della pressione indotta dal carico. Valve should be set at 1.3 times load induced pressure.

ESEMPIO/EXAMPLE:

Pressione di lavoro max

350 bar / 1.3 = 270 bar

Max working pressure

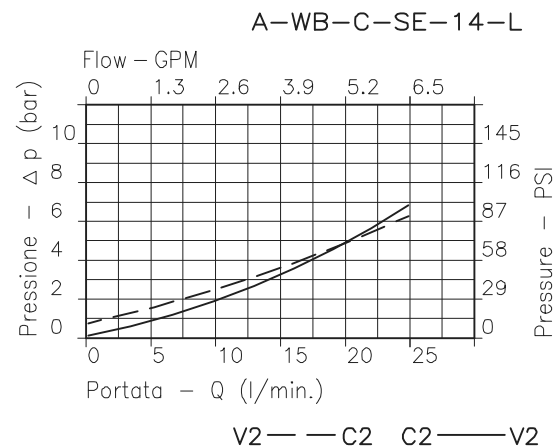
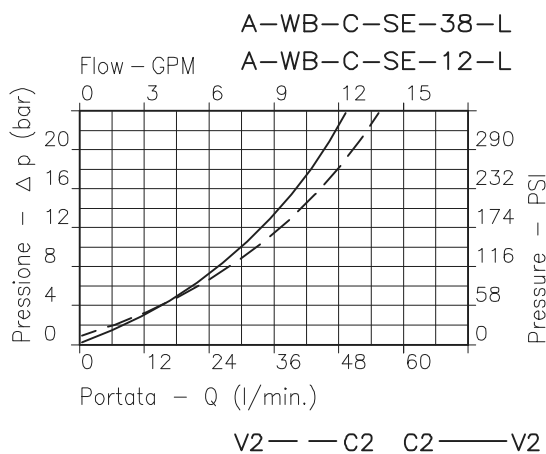

VALVOLA BILANCIAMENTO, BLOCCO E CONTROLLO MOVIMENTO A SEMPLICE EFFETTO CON COLLETTORE IN LINEA
SINGLE COUNTERBALANCE VALVE WITH IN LINE BODY

REGOLAZIONE
ADJUSTMENT →

Grano
Dowel
(X)

Piombata
Sealed
(K)

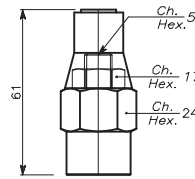
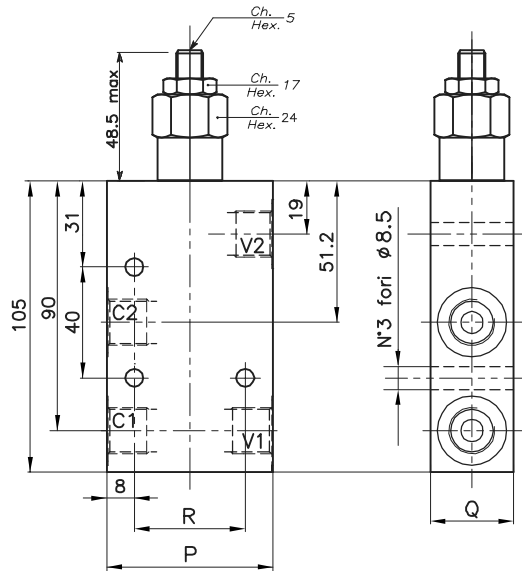

ESEMPIO TIPICO DI CIRCUITO
TYPICAL CIRCUIT EXAMPLE

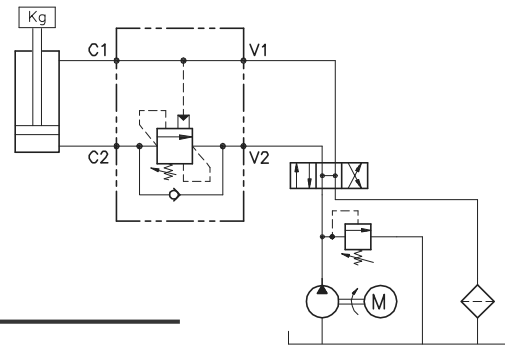

DIMENSIONI
DIMENSIONS

Campo taratura Setting range		P	Q	R	Attacchi Port size V2-C2 V1-C1 GAS (BSPP)	Luce nominale Rated size	Portata max Max flow-rate
						DN	l/min - GPM
328	327	60	30	40	3/8"	8	40-10
330	329	70	35	50	1/2"	10	60-15

CODICE DI ORDINAZIONE
HOW TO ORDER

N01 . 328 . 0 X 0 . A

Campo taratura / Setting range				Rapporto di pilotaggio Pilot ratios	Regolazione Adjustment	Collettore Body
328	327	330	329			
Campo taratura 30÷220 bar (molla colore verde)		Campo taratura 60÷350 bar (molla colore giallo)		O 4,25: 1	X Grano - Dowel	A Acciaio zincato Zinc plated steel
Setting range 30÷220 bar (green spring)		Setting range 60÷350 bar (yellow spring)		D 8: 1	K Piombata - Sealed	
Taratura standard (Q=5 l/1')	Incr. press. - bar giro/vite	Taratura standard (Q=5 l/1')	Incr. press. - bar giro/vite			
Std. bar setting (Q=5 l/1')	Pressure rise - turn of screw	Std. bar setting (Q=5 l/1')	Pressure rise - turn of screw			
180 bar	(50)	250 bar	(90)			
				327	Collettore possibile in AL togliendo "A"	
				328		
				329	Available aluminium body without "A"	
				330		