



## V\*P PRESSURE CONTROL VALVES PLATE V\*L PRESSURE CONTROL VALVES IN LINE

These pressure control valves are available in the basic VMP\* maximum pressure, VSP\* sequence and VUP\* exclusion versions, with a single pressure value and three calibration ranges that cover the band 15 ÷ 400 bar. It is possible to use auxiliary pilot valves, which can be the simple standard AD3E solenoid valve, by the mere exchange of covers.

**These valves have been fitted with an important safety feature for the operation of the system where they are used; a mechanical end of stroke stop prevents the operator from setting pressure values higher than those specified in the catalogue (it is impossible to compress the spring completely). In the standard configuration these valves are supplied with a 1.6 bar main spring and with calibrated ø1 mm pilot feed orifice (Variant part No. 00).**

Pressure max.	400 bar	
Setting ranges	Spring 1	15 ÷ 45 bar
	Spring 2	15 ÷ 145 bar
	Spring 3	45 ÷ 400 bar
Max. flow V*P16...	150 l/min	
Max. flow V*P25...	350 l/min	
Hydraulic fluids	Mineral oils DIN 51524	
Fluid viscosity	10 ÷ 500 mm <sup>2</sup> /s	
Fluid temperature	-25°C ÷ 75°C	
Ambient temperature	-25°C ÷ 60°C	
Max. contamination level	class 10 in accordance with NAS 1638 with filter β <sub>25</sub> ≥ 75	
Drainage V*P16...	1 ÷ 2 l/min	
Drainage V*P25...	1 ÷ 2.5 l/min	
Dynamic pressure at drainage	Max. 2 bar	
Weight V*P16... (without pilot valve)	3,3 Kg	
Weight V*P25... (without pilot valve)	7,4 Kg	
Weight V*L16... (without pilot valve)	4,6 Kg	
Weight V*L161... (without pilot valve)	4,5 Kg	
Weight V*L251... (without pilot valve)	7,7 Kg	
Weight V*L25... (without pilot valve)	8,3 Kg	

Subplate mounting valves are suitable for covers which do not conform to DIN standards type C\*P16/25.. whilst in line mounting valves are suitable for DIN standards covers type KEC16/25...

V*P / V*L...	
V*P...	CAP. II • 7
V*PE...	CAP. II • 8
V*L...	CAP. II • 9 - CAP. II • 10
BSVMP...	CAP. II • 11
KEC16/25...	CAP. II • 9
C*P16/25...	CAP. II • 9
CETOP 3/NG06	CAP. II • 8
STANDARD SPOOLS FOR AD3E	CAP. II • 10
AD3E...	CAP. II • 11
AM3VM...	CAP. II • 9

### ORDERING CODE

<b>V</b>	Valve
<b>*</b>	<b>M</b> = maximum pressure <b>S</b> = sequence <b>U</b> = exclusion (areas rep. 1,15 : 1)
<b>*</b>	<b>P</b> = Plate mounting <b>L</b> = In line mounting
<b>*</b>	<b>E</b> = Presetting for solenoid valve <b>Not for sequencing valve V.S.P...</b> (omit if not required)
<b>***</b>	Size (see overall dimensions) <b>16 - 25</b> = NG16 or NG25 <b>161 - 251</b> = for V*.L... only (in line mounting valve)
<b>*</b>	Type of adjustment: <b>M</b> = Plastic knob <b>C</b> = Grub screw
<b>*</b>	Setting ranges <b>1</b> = 15 ÷ 45 bar ( <b>white spring</b> ) <b>2</b> = 15 ÷ 145 bar ( <b>yellow spring</b> ) <b>3</b> = 45 ÷ 400 bar ( <b>green spring</b> )
<b>**</b>	<b>00</b> = No variant <b>V1</b> = Viton <b>AC</b> = Exclusion valve for accumulators (only for VU*, logic element areas rep. 12.5 : 1) <b>AQ</b> = Presetting for XP3
<b>2</b>	Serial No.

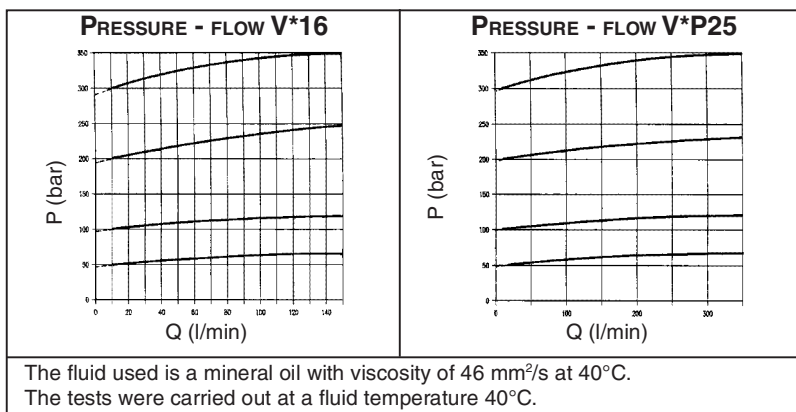

### HYDRAULIC SYMBOLS

<b>VMP16**...</b> <b>VMP25**...</b> <b>Maximum pressure valve</b> Internal piloting and draining			
<b>VSP16**...</b> <b>VSP25**...</b> <b>Sequencing valve</b> Internal piloting External draining			
<b>VUP16**...</b> <b>VUP25**...</b> <b>Exclusion valve</b> External piloting Internal draining			

# V\*P... PRESSURE CONTROL VALVES PLATE

## OVERALL DIMENSIONS V\*P16...

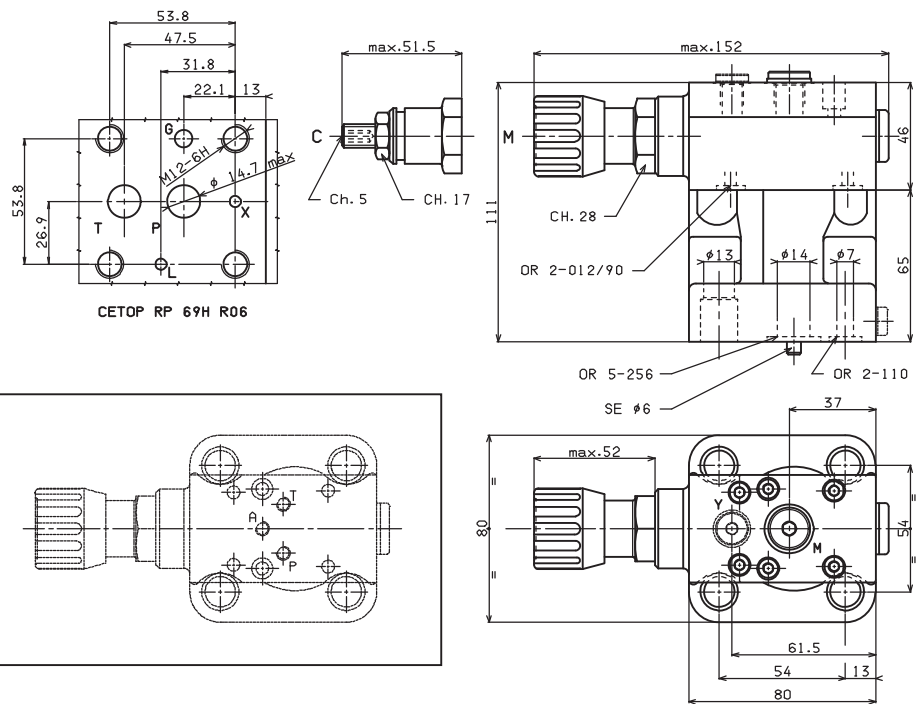

**VERSION WITH  
PRESETTING FOR  
SOLENOID VALVE**

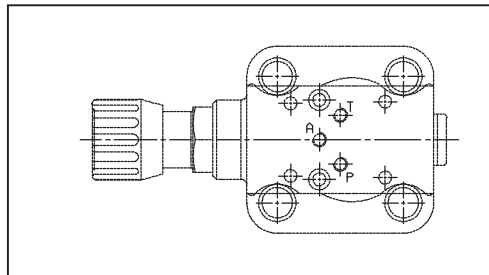

Fixing screws UNI 5931 M12x40 with material specifications min. 8.8  
Tightening torque 70 Nm / 7 Kgm

**M** = 1/4" BSP connector for pressure gauge for maximum pressure valve version only  
**Y** = 1/8" BSP external draining for sequencing valve version only

Support plane specifications

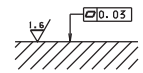

## OVERALL DIMENSIONS V\*P25...

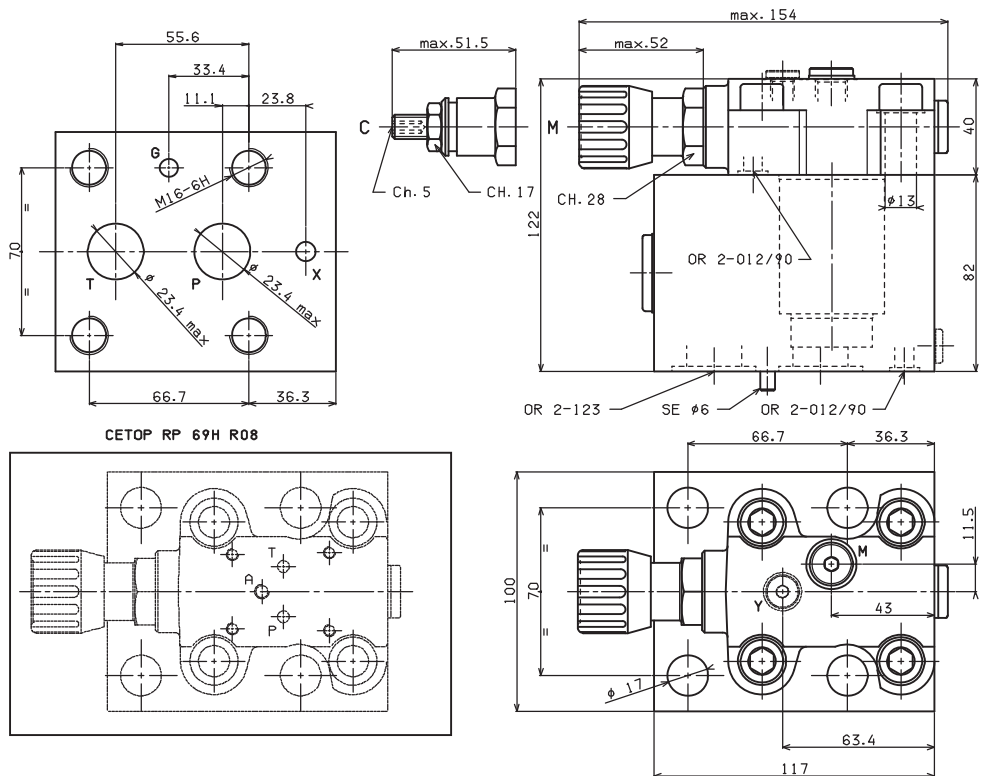

**VERSION WITH  
PRESETTING FOR  
SOLENOID VALVE**

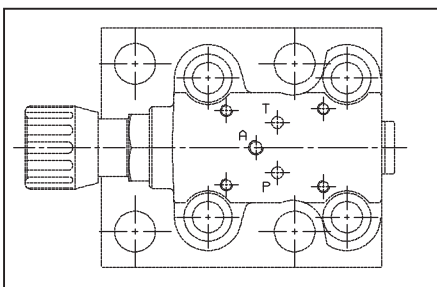

Fixing screws UNI 5931 M16x100 with material specifications min. 8.8  
Tightening torque 70 Nm / 7 Kgm

**M** = 1/4" BSP connector for pressure gauge for maximum pressure valve version only  
**Y** = 1/8" BSP external draining for sequencing valve version only

Support plane specifications

