



V*P / V*L...

V*P...	CAP. II • 7
V*PE...	CAP. II • 8
V*L...	CAP. II • 9 - CAP. II • 10
BSVMP...	CAP. II • 11
KEC16/25...	CAP. II • 9
C*P16/25...	CAP. II • 9
CETOP 3/NG06	CAP. II • 8
STANDARD SPOOLS FOR AD3E	CAP. II • 10
AD3E...	CAP. II • 11
AM3VM...	CAP. II • 9

ORDERING CODE

V

Valve

*

M = maximum pressure
S = sequence
U = exclusion
(areas rep. 1, 15 : 1)

*

P = Plate mounting
L = In line mounting

*

E = Presetting for solenoid valve
Not for sequencing valve V.S.P...
(omit if not required)

Size (see overall dimensions)
16 - 25 = NG16 or NG25
161 - 251 = for V*.L... only
(in line mounting valve)

*

Type of adjustment:
M = Plastic knob
C = Grub screw

*

Setting ranges
1 = 15 ÷ 45 bar (**white spring**)
2 = 15 ÷ 145 bar (**yellow spring**)
3 = 45 ÷ 400 bar (**green spring**)

**

00 = No variant
V1 = Viton
AC = Exclusion valve for accumulators (only for VU*, logic element areas rep. 12.5 : 1)
AQ = Presetting for XP3

2

Serial No.

V*P PRESSURE CONTROL VALVES PLATE

V*L PRESSURE CONTROL VALVES IN LINE

These pressure control valves are available in the basic VMP* maximum pressure, VSP* sequence and VUP* exclusion versions, with a single pressure value and three calibration ranges that cover the band 15 ÷ 400 bar. It is possible to use auxiliary pilot valves, which can be the simple standard AD3E solenoid valve, by the mere exchange of covers.

These valves have been fitted with an important safety feature for the operation of the system where they are used; a mechanical end of stroke stop prevents the operator from setting pressure values higher than those specified in the catalogue (it is impossible to compress the spring completely). In the standard configuration these valves are supplied with a 1.6 bar main spring and with calibrated $\phi 1$ mm pilot feed orifice (Variant part No. 00).

Pressure max.		400 bar
Setting ranges	Spring 1	15 ÷ 45 bar
	Spring 2	15 ÷ 145 bar
	Spring 3	45 ÷ 400 bar
Max. flow V*P16...		150 l/min
Max. flow V*P25...		350 l/min
Hydraulic fluids		Mineral oils DIN 51524
Fluid viscosity		10 ÷ 500 mm ² /s
Fluid temperature		-25°C ÷ 75°C
Ambient temperature		-25°C ÷ 60°C
Max. contamination level	class 10 in accordance with NAS 1638 with filter $\beta_{25} \geq 75$	
Drainage V*P16...		1 ÷ 2 l/min
Drainage V*P25...		1 ÷ 2.5 l/min
Dynamic pressure at drainage		Max. 2 bar
Weight V*P16... (without pilot valve)		3,3 Kg
Weight V*P25... (without pilot valve)		7,4 Kg
Weight V*L16... (without pilot valve)		4,6 Kg
Weight V*L161... (without pilot valve)		4,5 Kg
Weight V*L251... (without pilot valve)		7,7 Kg
Weight V*L25... (without pilot valve)		8,3 Kg

Subplate mounting valves are suitable for covers which do not conform to DIN standards type C*P16/25.. whilst in line mounting valves are suitable for DIN standards covers type KEC16/25...

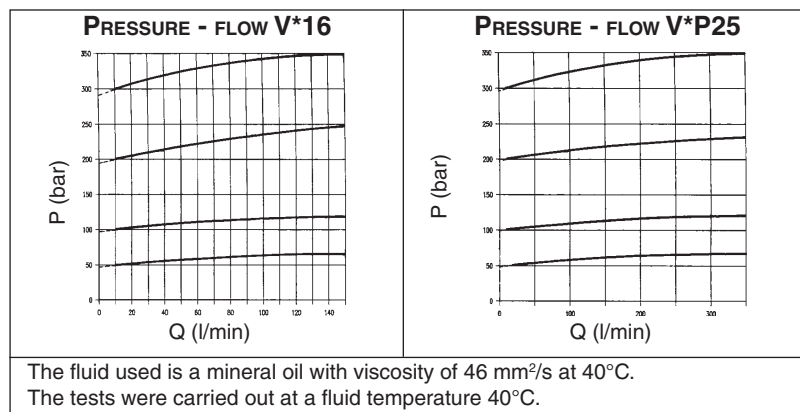

HYDRAULIC SYMBOLS

VMP16**... VMP25**... Maximum pressure valve Internal piloting and draining		
VSP16**... VSP25**... Sequencing valve Internal piloting External draining		
VUP16**... VUP25**... Exclusion valve External piloting Internal draining		

V*P... PRESSURE CONTROL VALVES PLATE

OVERALL DIMENSIONS V*P16...

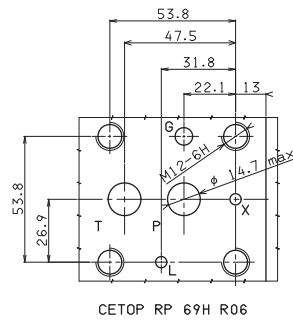

CETOP RP 69H R06

**VERSION WITH
PRESETTING FOR
SOLENOID VALVE**

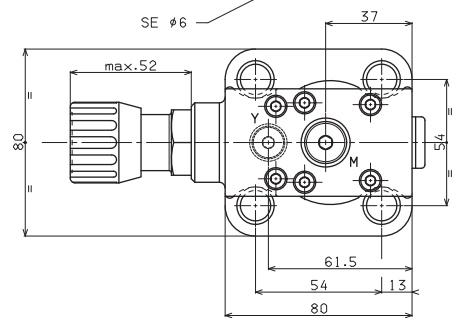
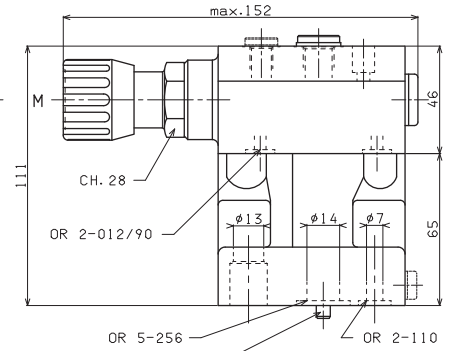
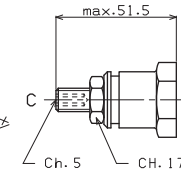
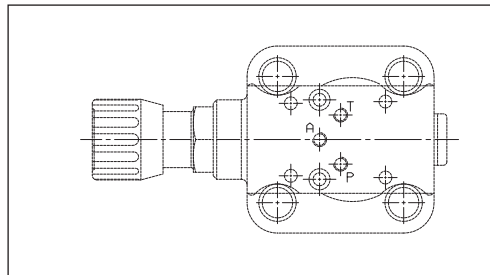

Fixing screws UNI 5931 M12x40 with material specifications min. 8.8
Tightening torque 70 Nm / 7 Kgm

M = 1/4" BSP connector for pressure gauge for maximum pressure valve version only
Y = 1/8" BSP external draining for sequencing valve version only

Support plane specifications

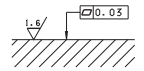

2

OVERALL DIMENSIONS V*P25...

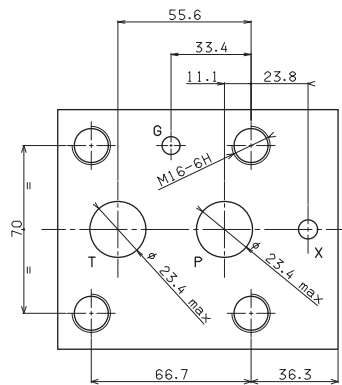

CETOP RP 69H R08

**VERSION WITH
PRESETTING FOR
SOLENOID VALVE**

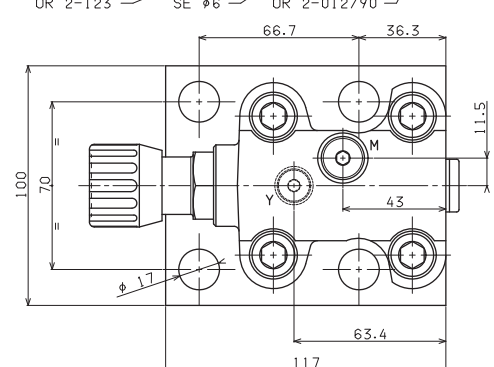
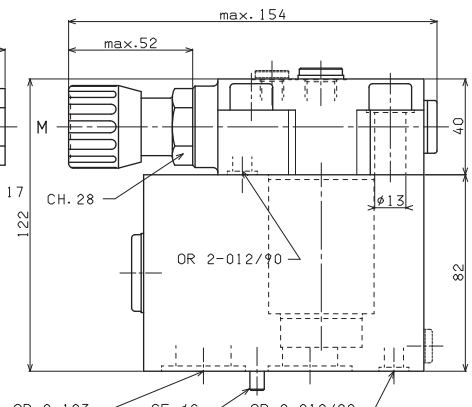
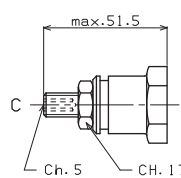
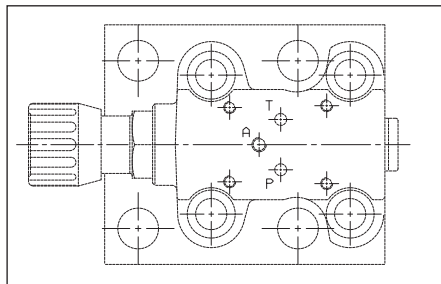

Fixing screws UNI 5931 M16x100 with material specifications min. 8.8
Tightening torque 70 Nm / 7 Kgm

M = 1/4" BSP connector for pressure gauge for maximum pressure valve version only
Y = 1/8" BSP external draining for sequencing valve version only

Support plane specifications

