

SERIE: 30980 12 Volt

SERIE: 30981 24 Volt

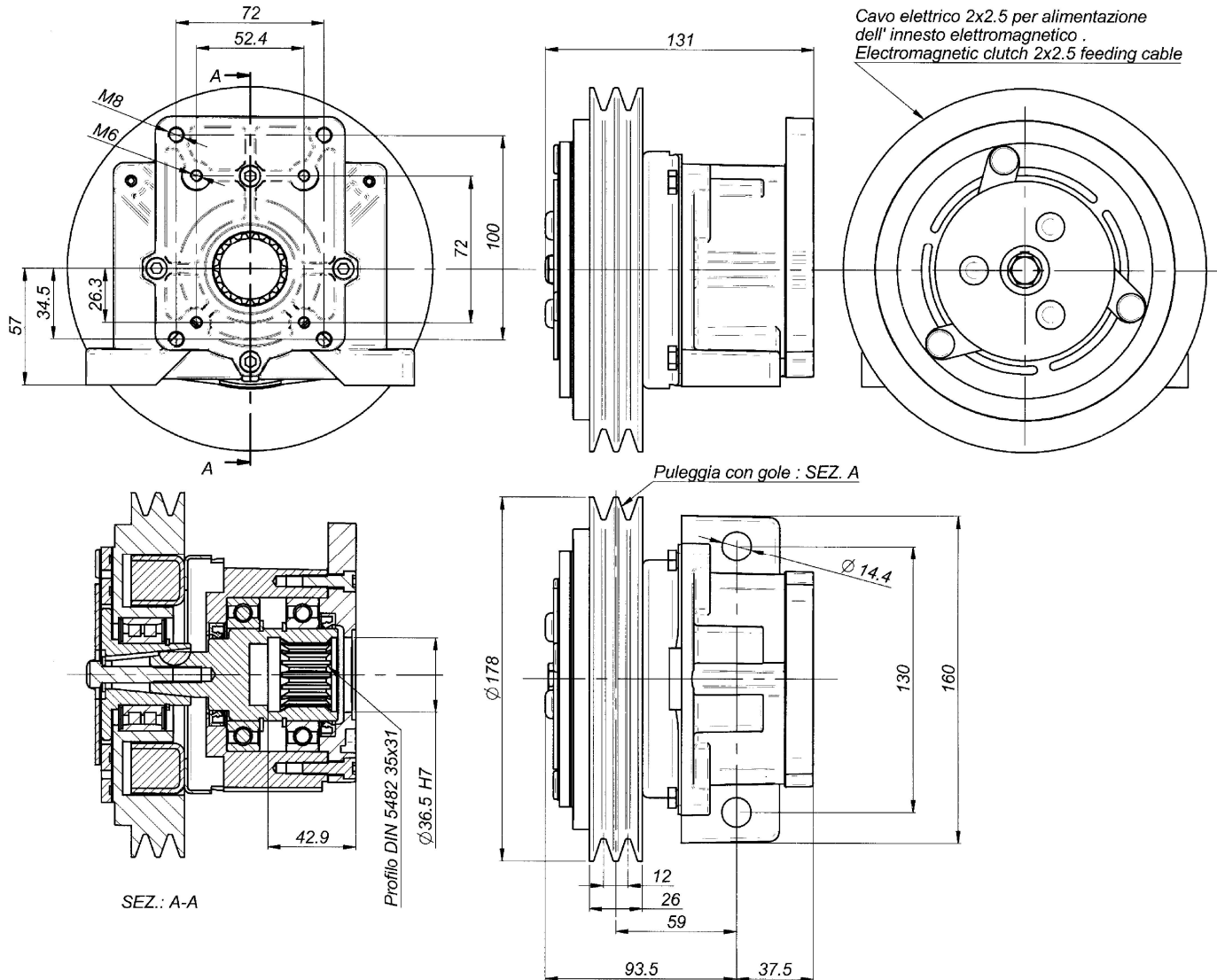

Nominal torque	11,8 daNm		Connection time	25 m/sec		
Static torque	14,0 daNm		Disconnection time	40 m/sec		
Dynamic torque	12,5 daNm	at 500 rpm	Minimum time between two connection	20 sec		
	11,0 daNm	at 1000 rpm				
	8,2 daNm	at 1500 rpm				
	7,5 daNm	at 2000 rpm	Max speed	5000 rpm		
	6,7 daNm	at 2500 rpm	Weight	5,8 Kg		
6,5 daNm	at 3000 rpm					
Electric absorption	Resistance ( $\Omega$ )		Current (A)		Power (W)	
	20° C	120° C	20° C	120° C	20° C	120° C
12 V DC	4,00	5,60	3,33	2,00	40,00	24,00
24 V DC	20,00	28,00	1,26	0,77	30,30	18,18
All technical data are at 20°C / at 120 °C the performance are less 20%						
All electromageteic clutches are reversible.						