

POTENZA
POWER

500 W

TENSIONE
TENSION

24 V

VELOCITA'
SPEED

1500 Rpm

COPPIA
TORQUE

3.2 Nm

PROTEZIONE
ENCLOSURE

IP 20

PESO
WEIGHT

10 Kg

CODICE
CODE

MP113.0285.01

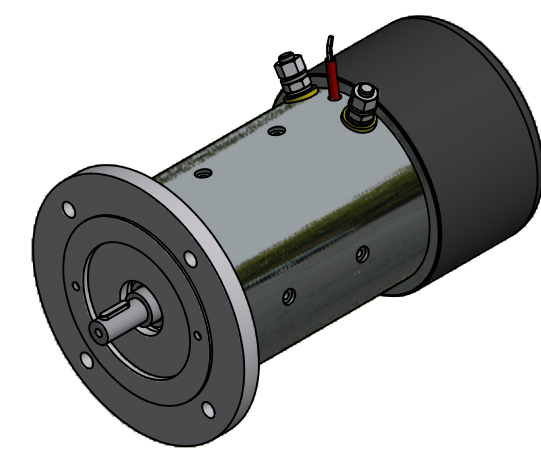
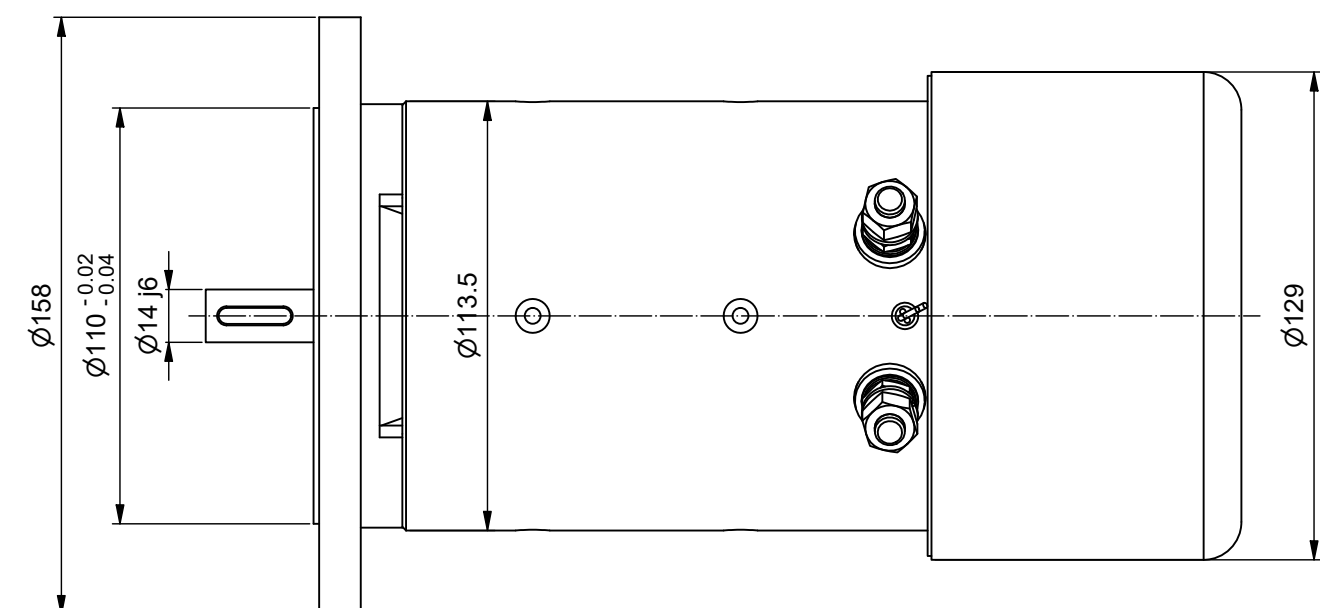
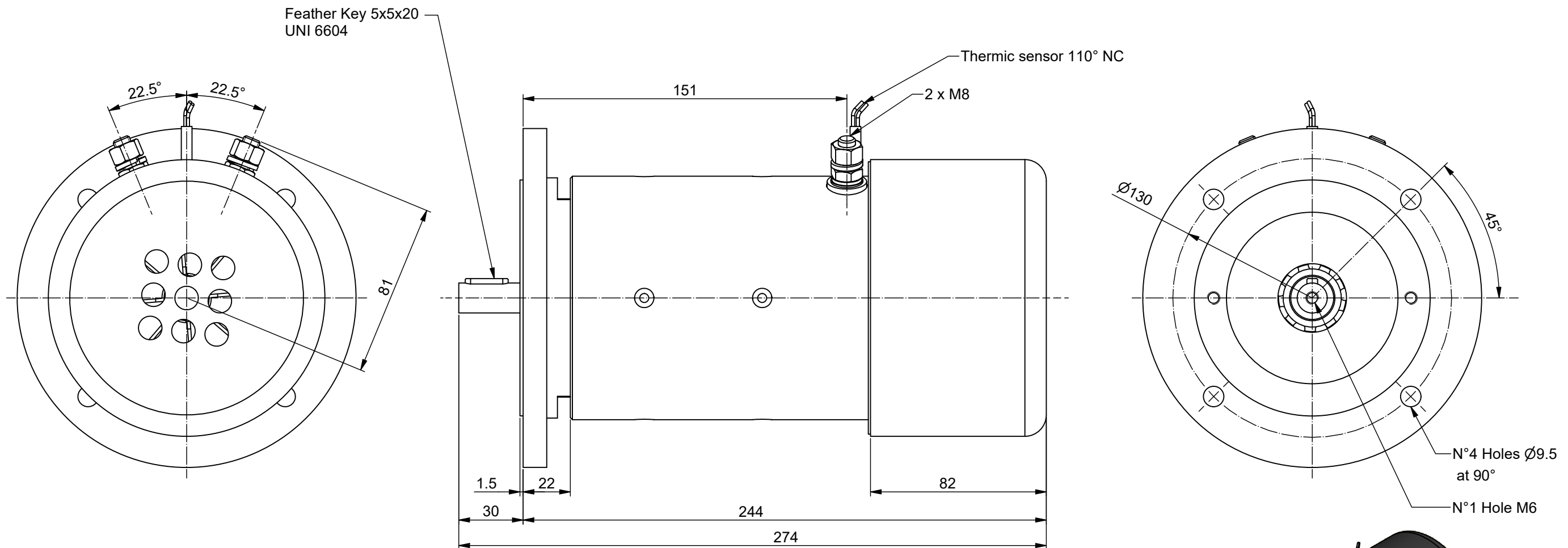

| | | | |
|--|---------------|---|-------------|
| B | | | |
| A | | | |
| Mod. : | Descrizione : | Firma : | Data Mod. : |
| Ref. : | Description : | Signature : | Ref. Date : |
| Tutti i diritti sono riservati. Nessun disegno, o parte di esso, può essere copiato, modificato o trasmesso in qualsiasi forma senza autorizzazione della C.F.R. | | All rights reserved. No designs, or part of them, may be copied, modified or transmitted in any form without permission of C.F.R. | |
| Prodotto : | DC MOTOR | | |
| Disegnato : | J.I. | Data : | 06/06/2023 |
| Drawn : | | Scale : | 1:2 |
| MP113 - 140 - B5/71 - VP | | | |
| | | | A3 |