

ORBITROL HKUS100-4-100 (CF.030036)

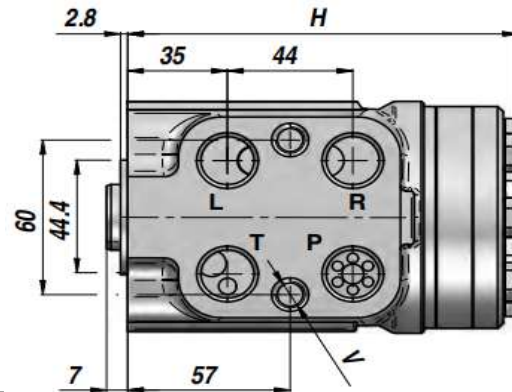
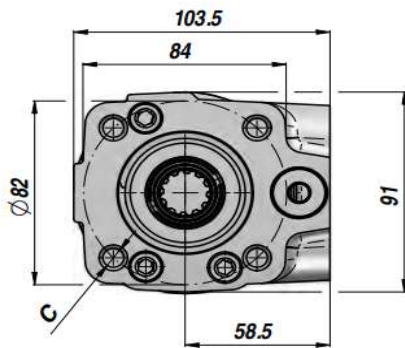

Maatvoering, poorten BSPP					
H	40	139	R	1/2	
P	1/2		L	1/2	
T	1/2				
C	M10x1		V	M10	

Maximale druk 170bar
 Slag volume 99cc/omw.
 Pilot ratio n.v.t.
 Openings druk n.v.t.
 Materiaal Staal
 Gewicht 6KG
 Standaard setting
 Overdruk ventiel 100 bar
 Shock valve 160 bar

Ingebouwde kleppen/ventielen:
 Shock valves + overdrukventiel, anti cavitatie kleppen.

Gerelateerd item, **Artikel nr. CF.030040** (L= 775mm) :

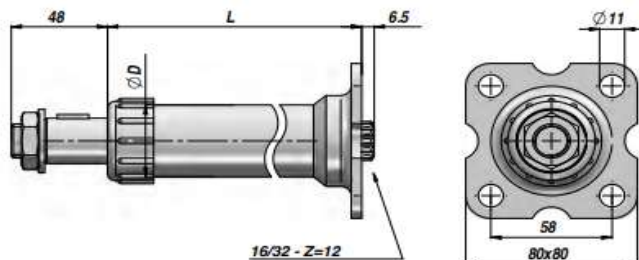

Gerelateerd item, **Artikel nr. CF.030050** (D= Ø 352mm / H= 105mm) :

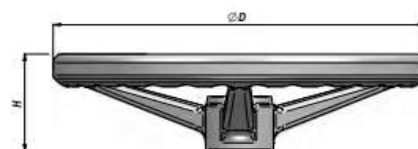

Artikel nr. CF.030060



Dop t.b.v. stuurwiel