

A-WB-CC-DE-LU-...-...

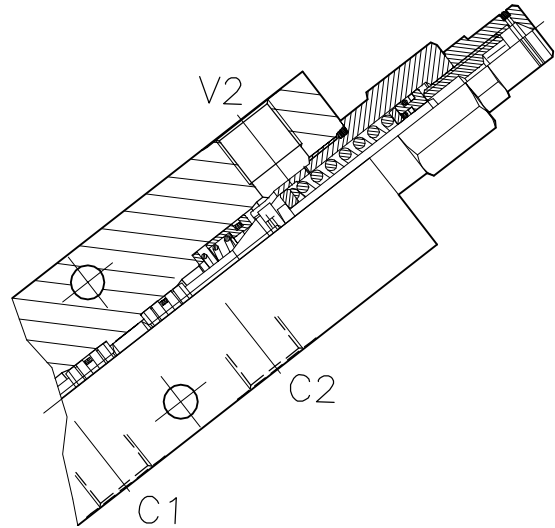
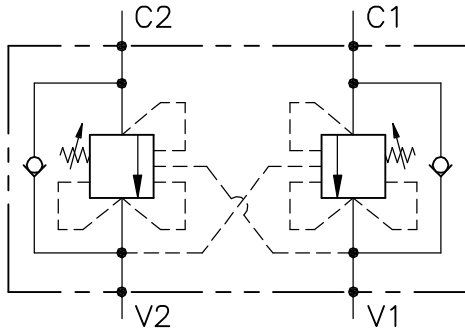

CARATTERISTICHE

Luce nominale	DN 8/10
Portata min/max	1/60 l/min - 0.26/15.9 GPM
Pressione max. di picco	350 bar - 5075 PSI
Pressione max. di taratura	350 bar - 5075 PSI
Rapporto di pilotaggio standard	Vedi tab. / See tab.
Temperatura ambiente	-30°C + 50°C
Temperatura olio	-30°C + 80°C
Filtraggio consigliato	30 micron

PERFORMANCE

Rated size
Min/max flow-rate
Max peak pressure
Max setting pressure
Standard pilot ratio
Room temperature
Oil temperature
Recommended filtration

NOTE:

La taratura deve essere 1.3 volte maggiore della pressione indotta dal carico. Valve should be set at 1.3 times load induced pressure.

ESEMPIO/EXAMPLE:

Pressione di lavoro max

350 bar / 1.3 = 270 bar

Max working pressure

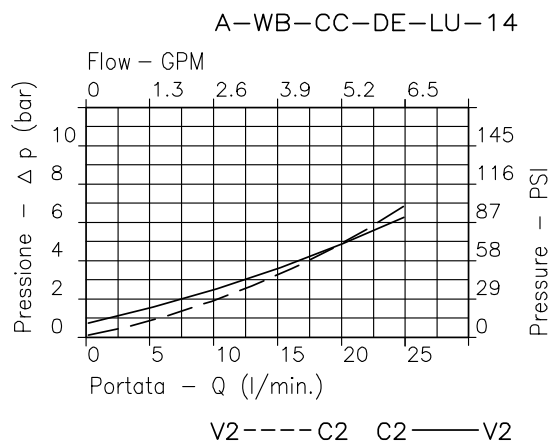
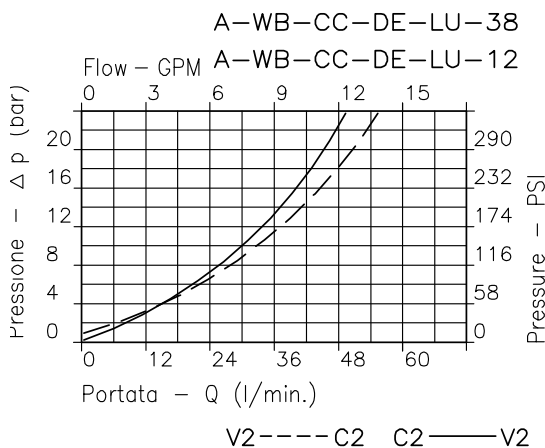

Viscosità olio 46 cSt a 50°C - Oil viscosity 46 cSt at 50°C

VALVOLA BILANCIAMENTO, BLOCCO E CONTROLLO MOVIMENTO PER CENTRO CHIUSO, A DOPPIO EFFETTO CON COLLETTORE IN LINEA
DOUBLE COUNTERBALANCE VALVE FOR CLOSED CENTRE SPOOL WITH IN LINE BODY

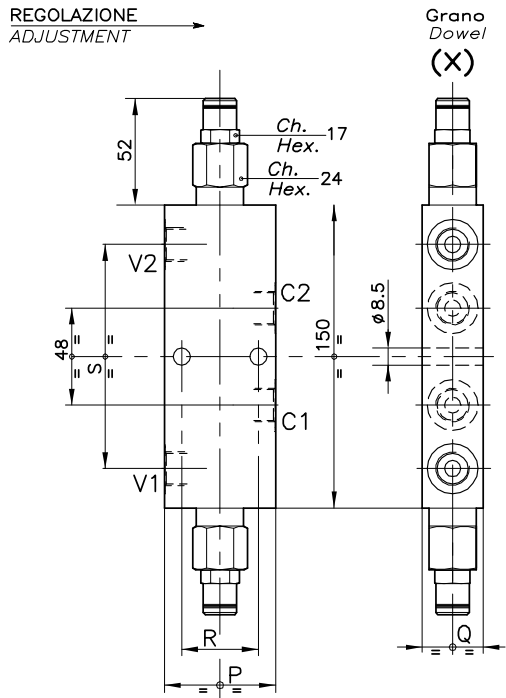

ESEMPIO TIPICO DI CIRCUITO
TYPICAL CIRCUIT EXAMPLE

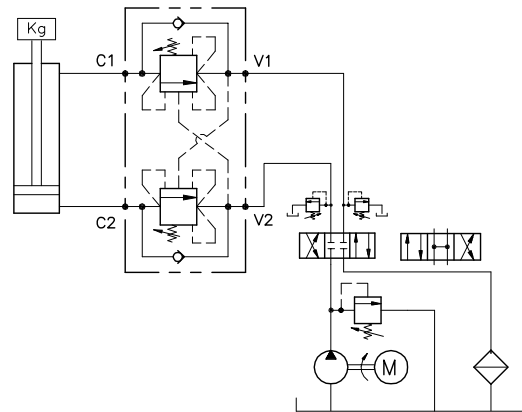

DIMENSIONI
DIMENSIONS

Campo taratura Setting range		P	Q	R	S	Attacchi Port size V2-C2 V1-C1 GAS (BSPP)	Luce nominale Rated size DN	Portata max Max flow-rate l/min - GPM
460	459	55	30	38	109.6	3/8"	8	40-10
462	461	65	35	43	112	1/2"	10	60-15

CODICE DI ORDINAZIONE
HOW TO ORDER

001 . 460 . 0 X 0 . A

Campo taratura / Setting range			
460		459	
462		461	
Campo taratura 30÷220 bar (molla colore verde)		Campo taratura 60÷350 bar (molla colore rosso)	
Setting range 30÷220 bar (green spring)		Setting range 60÷350 bar (red spring)	
Taratura standard (Q=5 l/1')	Incr. press. - bar giro/vite	Taratura standard (Q=5 l/1')	Incr. press. - bar giro/vite
Std. bar setting (Q=5 l/1')	Pressure rise - turn of screw	Std. bar setting (Q=5 l/1')	Pressure rise - turn of screw
180 bar	(60)	250 bar	(140)

Rapporto di pilotaggio Pilot ratios	Regolazione Adjustment	Collettore Body
0 4.25: 1	X Grano - Dowel	A Acciaio zincato Zinc plated steel

461	
462	Collettore possibile in AL togliendo "A"
460	Available aluminium body without "A"
459	