

CC.030530

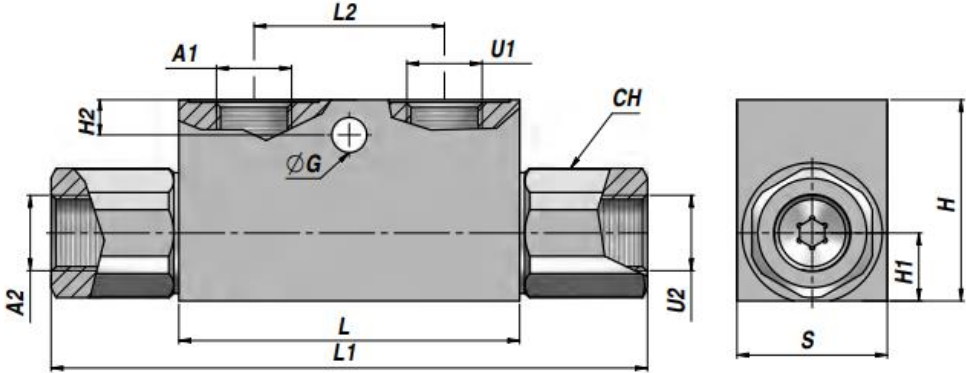
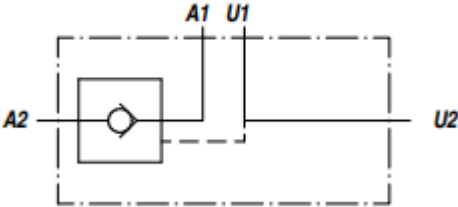

A1 - U1 BSP	A2 - U2 BSP	Q MAX l/min	P MAX bar	PILOT RATIO	Typo Type	L	L1	L2	H1	H2	ØG	CH	H	S	kg
1/2"	1/2"	50	300	1:4	VRSE-F 025 FF	80	144	40	16	15	8.5	27	50	30	0,90