

Type T3A 802-2

Cod. R080Y201,1AA5A00000T

Mounting position

IM	B35
IM	2001

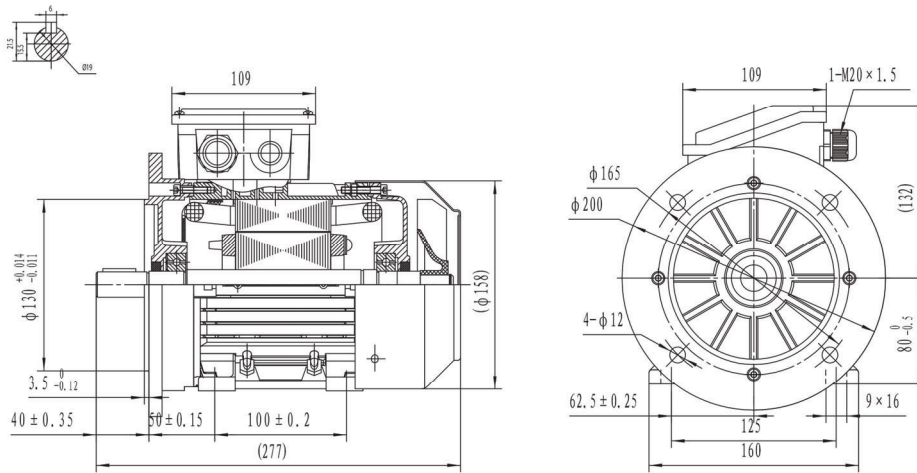

Electrical data			
Rated motor power	1.1		Kw
Rated motor speed	2900		min^{-1} 50Hz
	3480		min^{-1} 60Hz
Rated motor frequency	50		Hz
Rated motor voltage(+/-10%)	230		V Δ /50Hz
	400		VY/50Hz
	280		V Δ /60Hz
	480		VY/60Hz
Rated motor torque	3.62		Nm (Mn)
Rated motor current	4.08	V Δ /50Hz	A (In)
	2.36	VY/50Hz	A (In)
Starting motor current	8.7		xIn
Starting motor torque	3.4		xMn
Breakdown motor torque	3.4		xMn
Starting			D.O.L.
Efficiency class	IE3		
Efficiency	50Hz	60Hz	
	82.7	82.8	100% load
	82.5	82.2	75% load
	79.9	81.6	50% load
Power factor cos ϕ	0.82	0.82	100% load

General data		
Frame size	80	
Mounting	B35	
Weight	10.71	Kg
Casing material	Aluminum	
Protection	IP	55
Insulation class	H	
Tropicalization	Yes	
Vibration class	A	
Duty	S1	
Direction of rotation	Bidirectional	
Method of cooling	IC	411
Cable entry	1-M20x1,5	
Standards	IEC/DIN/ISO/VDE/EN	
Execute at Standard	IEC 60034-1	
Feet removable	Yes	
Paintwork	7024	C2 standard
Thermal protections	n/a	

Site conditions	
Ambient temperature	from -20°C to +40°C
Altitude above sea level	1000 m

Mechanical data					
Noise level	LpA	75	dB(A)	Bearing DE side	6204-2RS-C3
	LwA	84	dB(A)	Bearing NDE side	6204-2RS-C3
Moment of inertia	0.00128		Kgm ²	Average bearing lifetime	40000 h
Bearings type			NSK	Relubrication interval L1 DE bearing	life h
Lubricants for bearings	See installation and maintenance manual			Relubrication interval L1 NDE bearing	life h
				Compensation ring	NDE SIDE

There may be differences between rating plate and calculated values.

NO LOAD

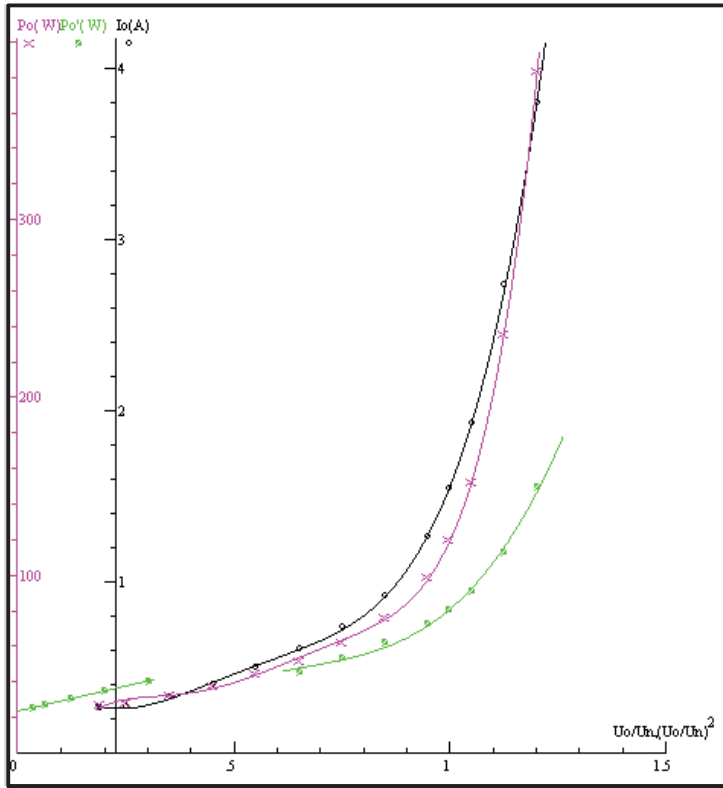

LOCKED ROTOR

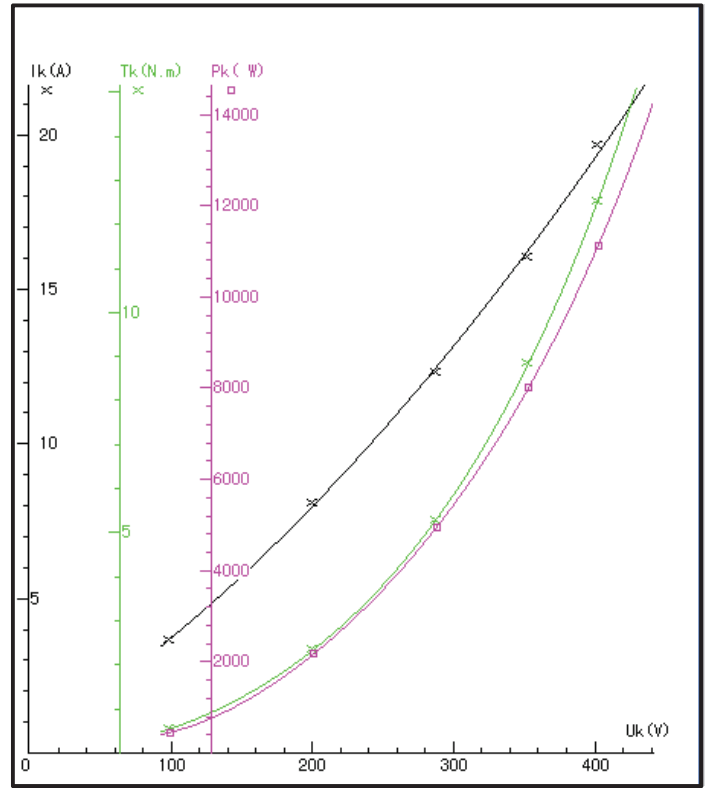

LOAD

