

Type T3A 90S-4

Cod. R090S401,1AA5A00000T

Mounting position

IM	B35
IM	2001

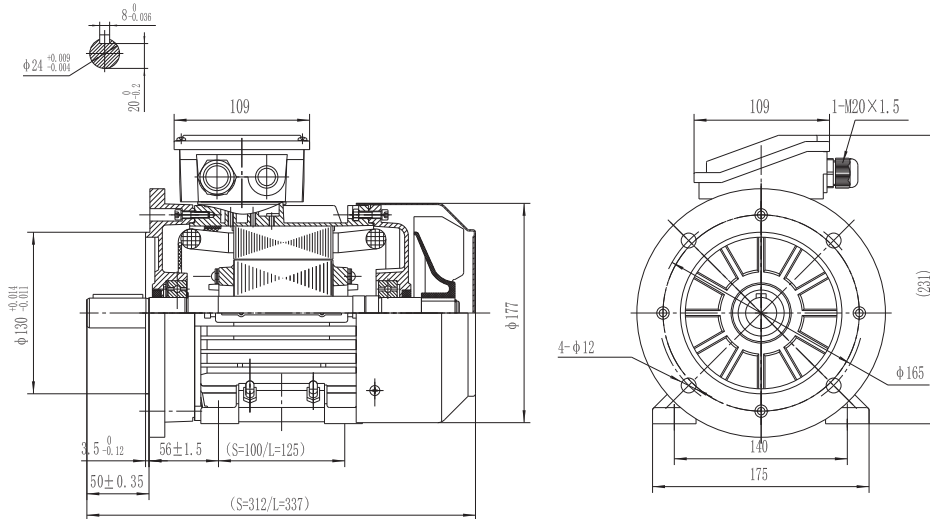

Electrical data			
Rated motor power	1.1		Kw
Rated motor speed	1440		min ⁻¹ 50Hz
	1730		min ⁻¹ 60Hz
Rated motor frequency	50		Hz
Rated motor voltage(+/-10%)	230		VΔ/50Hz
	400		VY/50Hz
	280		VΔ/60Hz
	480		VY/60Hz
Rated motor torque	7.3		Nm (Mn)
	4.44	VΔ/50Hz	A (In)
Rated motor current	2.57	VY/50Hz	A (In)
	7.1		xIn
Starting motor torque	4		xMn
Breakdown motor torque	3.4		xMn
Starting			D.O.L.
Efficiency class	IE3		
Efficiency	50Hz	60Hz	
	84.1	84.3	100% load
	84.1	83.7	75% load
	81.8	83	50% load
Power factor cosφ	0.74	0.74	100% load

General data		
Frame size	90	
Mounting	B35	
Weight	15.86	Kg
Casing material	Aluminum	
Protection	IP	55
Insulation class	H	
Tropicalization	Yes	
Vibration class	A	
Duty	S1	
Direction of rotation	Bidirectional	
Method of cooling	IC	411
Cable entry	1-M20x1,5	
Standards	IEC/DIN/ISO/VDE/EN	
Execute at Standard	IEC 60034-1	
Feet removable	Yes	
Paintwork	7024	C2 standard
Thermal protections	n/a	

Site conditions	
Ambient temperature	from -20°C to +40°C
Altitude above sea level	1000 m

Mechanical data					
Noise level	LpA	70	dB(A)	Bearing DE side	6205-2RS-C3
	LwA	80	dB(A)	Bearing NDE side	6205-2RS-C3
Moment of inertia	0.00384		Kgm ²	Average bearing lifetime	40000 h
Bearings type			NSK	Relubrication interval L1 DE bearing	life h
Lubricants for bearings	See installation and maintenance manual			Relubrication interval L1 NDE bearing	life h
				Compensation ring	NDE SIDE

There may be differences between rating plate and calculated values.

Type: T3A90S-4 Voltage: 400/230 V
 Output 1,1 KW Connection: Y/Δ
 Frequency: 50 Hz Duty: S1

Test Item		Standard		Result	
		Nominal	Tol		
1	Efficiency %			84,9	
2	Power Factor			0,725	
3	Tem. Rise of Stator Winding K			36,4	
4	Vibration mm/s				
5	Noise Lp dB (A) (Lw)				
6	Breakdown Torque/Rated Torque			3,12	
7	Pullup Torque/Rated Torque			2,48	
8	Locked Rotor Tor./Rated Tor.			3,08	
9	Locked Rotor Cur./Rated Cur.			6,74	
10	High Voltage Test V			1800	
11	Hot Insulation Res. of Stator Winding MΩ			300	
12	Temperature of Bearing °C			54	
13	Unbalance of Current %			3,39	
14	Full Load line Current A			2,581	
15	Full-load input power (W)			1295,6	
16	Full Load torque Nm			7,2613	
17	Max.temp.of enclosure surface °C			51,9	
18	No Load Current A			1,682	
19	Slip %			3,7778	
20	Winding phase resistance 95 °C			5,2776	
21	Stary-load loss (W)			15,024	
22	No-load input power (W)			80,373	
23	Core loss (W)			32,649	
24	Friction and wind age loss(W)			8,8331	
25	Locked Rotor Power (W)			7698	
26	StatorI2Rloss (W)			94,969	
27	RotorI2Rloss (W)			44,124	
28	Locked Rotor Voltage 100 V	Current A	2,837	Power W	233,8
50%eff: 85,385 75%eff: 83,825					

NO LOAD

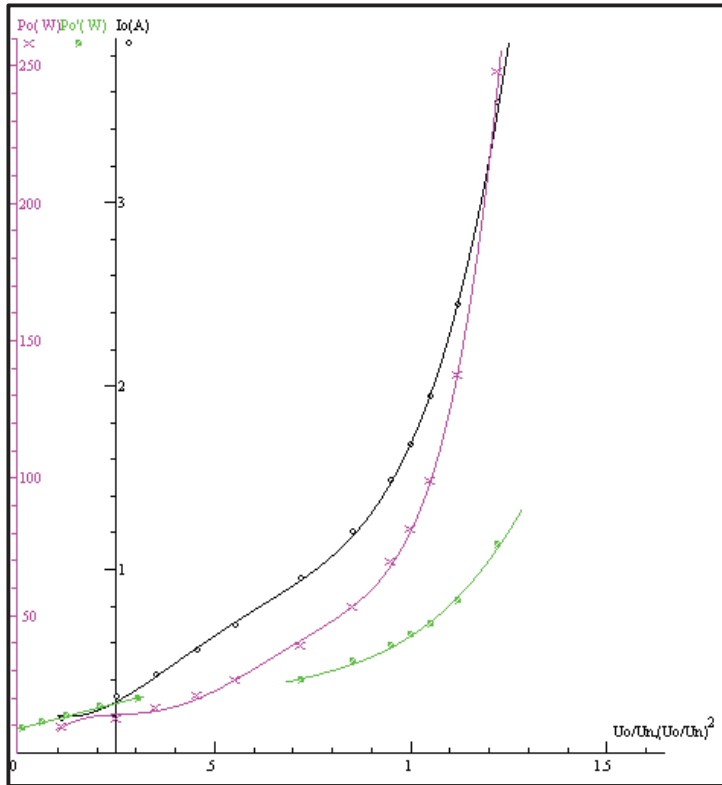

LOCKED ROTOR

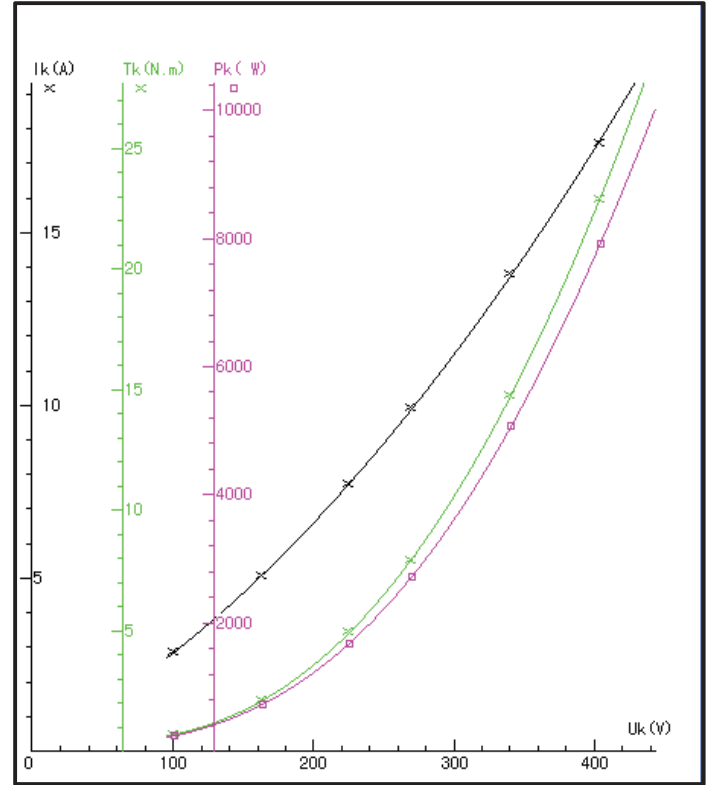

LOAD

