

Type T3A 90L1-2

Cod. R090L202,2AA5A00000T

Mounting position

IM	B35
IM	2001

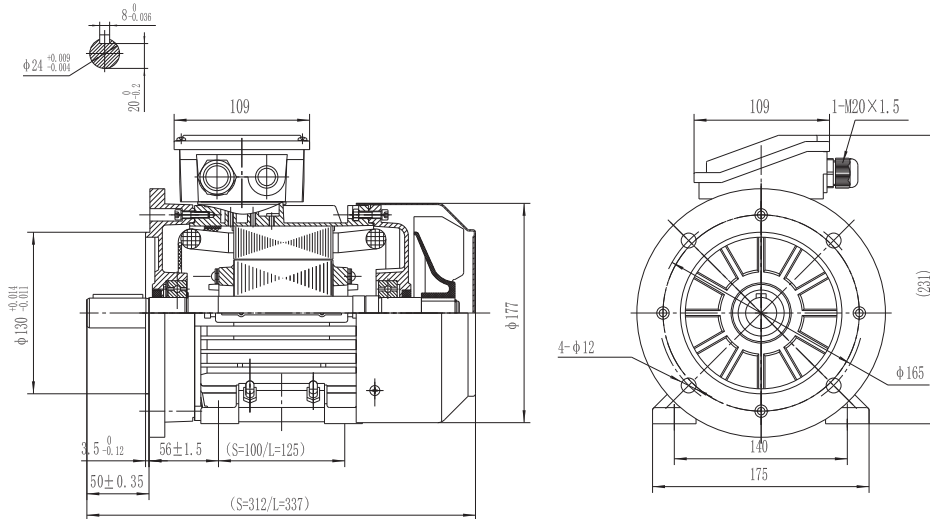

Electrical data			
Rated motor power	2.2		Kw
Rated motor speed	2910		min ⁻¹ 50Hz
	3495		min ⁻¹ 60Hz
Rated motor frequency	50		Hz
Rated motor voltage(+/-10%)	230		VΔ/50Hz
	400		VY/50Hz
	280		VΔ/60Hz
	480		VY/60Hz
Rated motor torque	7.22		Nm (Mn)
	7.66	VΔ/50Hz	A (In)
Rated motor current	4.43	VY/50Hz	A (In)
	8.1		xIn
Starting motor torque	3.1		xMn
Breakdown motor torque	3.5		xMn
Starting			D.O.L.
Efficiency class	IE3		
Efficiency	50Hz	60Hz	
	85.9	85.9	100% load
	86.1	85.3	75% load
	84.7	84.6	50% load
Power factor cosφ	0.84	0.84	100% load

General data		
Frame size	90	
Mounting	B35	
Weight	16.02	Kg
Casing material	Aluminum	
Protection	IP	55
Insulation class	H	
Tropicalization	Yes	
Vibration class	A	
Duty	S1	
Direction of rotation	Bidirectional	
Method of cooling	IC	411
Cable entry	1-M20x1,5	
Standards	IEC/DIN/ISO/VDE/EN	
Execute at Standard	IEC 60034-1	
Feet removable	Yes	
Paintwork	7024	C2 standard
Thermal protections	n/a	

Site conditions	
Ambient temperature	from -20°C to +40°C
Altitude above sea level	1000 m

Mechanical data						
Noise level	LpA	75	dB(A)	Bearing DE side	6205-2RS-C3	
	LwA	85	dB(A)	Bearing NDE side	6205-2RS-C3	
Moment of inertia	0.00264		Kgm ²	Average bearing lifetime	40000 h	
Bearings type			NSK	Relubrication interval L1 DE bearing	life h	
Lubricants for bearings	See installation and maintenance manual			Relubrication interval L1 NDE bearing	life h	
				Compensation ring		NDE SIDE standard

There may be differences between rating plate and calculated values.

NO LOAD

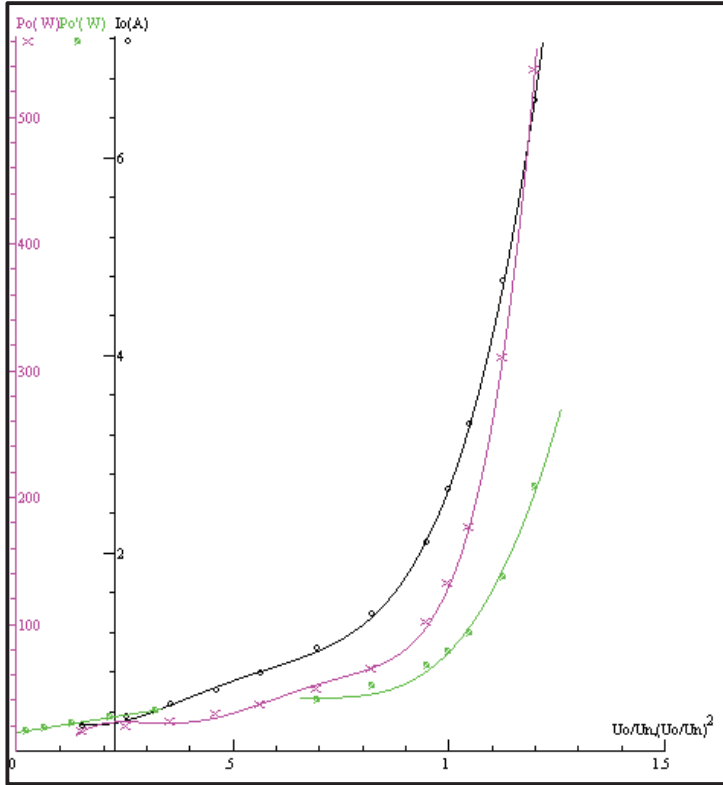

LOCKED ROTOR

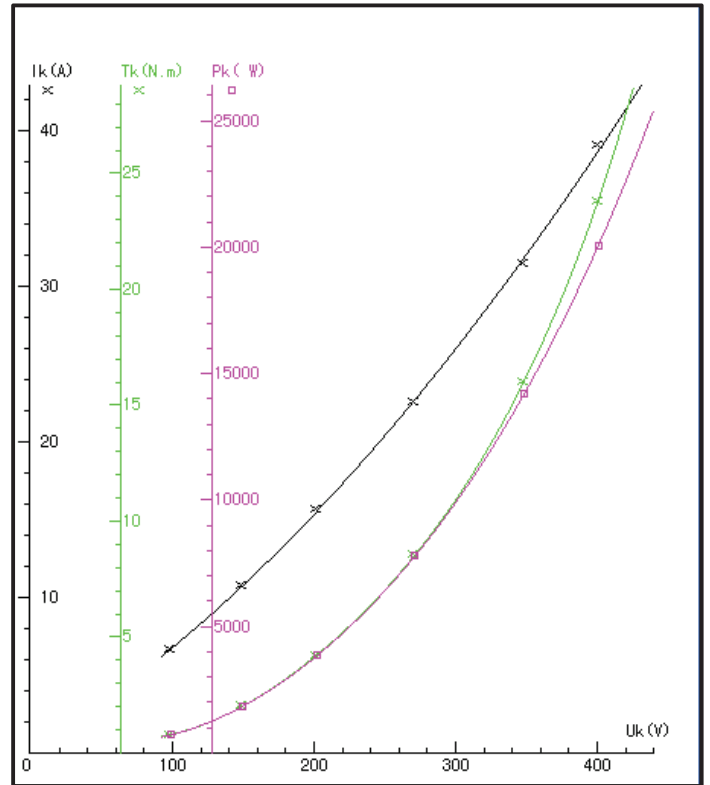

LOAD

