

Type T2A 100L2-6

Cod. I100L602,2AA5A00000T

Mounting position

IM	B35
IM	2001

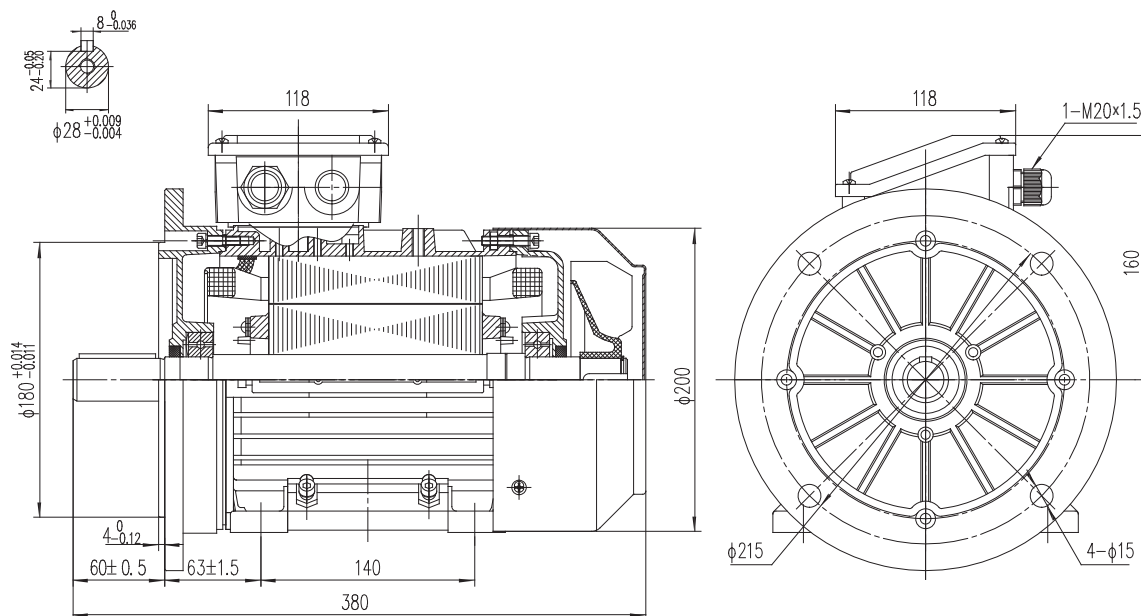

Electrical data			
Rated motor power	2.2		Kw
Rated motor speed	950		min ⁻¹ 50Hz
	1140		min ⁻¹ 60Hz
Rated motor frequency	50		Hz
Rated motor voltage(+/-10%)	230		VΔ/50Hz
	400		VY/50Hz
	280		VΔ/60Hz
	480		VY/60Hz
Rated motor torque	22.13		Nm (Mn)
Rated motor current	9.39	VΔ/50Hz	A (In)
	5.43	VY/50Hz	A (In)
Starting motor current	5.5		xIn
Starting motor torque	2.5		xMn
Breakdown motor torque	2.7		xMn
Starting			D.O.L.
Efficiency class	IE2		
Efficiency	50Hz	60Hz	
	81.8	-	100% load
	82.6	-	75% load
	81.1	-	50% load
Power factor cosφ	0.72	-	100% load

General data		
Frame size	100	
Mounting	B35	
Weight	-	Kg
Casing material	Aluminum	
Protection	IP	55
Insulation class	H	
Tropicalization	Yes	
Vibration class	A	
Duty	S1	
Direction of rotation	Bidirectional	
Method of cooling	IC	411
Cable entry	2-M20x1,5	
Standards	IEC/DIN/ISO/VDE/EN	
Execute at Standard	IEC 60034-1	
Feet removable	Yes	
Paintwork	7024	C2 standard
Thermal protections	n/a	

Site conditions	
Ambient temperature	from -20°C to +40°C
Altitude above sea level	1000 m

Mechanical data					
Noise level	LpA	66	dB(A)	Bearing DE side	6206-2RS-C3
	LwA	76	dB(A)	Bearing NDE side	6206-2RS-C3
Moment of inertia	0.01153		Kgm ²	Average bearing lifetime	40000 h
Bearings type			NSK	Relubrication interval L1 DE bearing	- h
Lubricants for bearings	See installation and maintenance manual			Relubrication interval L1 NDE bearing	- h
				Compensation ring	NDE SIDE

There may be differences between rating plate and calculated values.

Type Test Report

Type: T2A100L2-6 Voltage: 400/230 V
 Output: 2.2 kW Connection: Y/Δ
 Frequency: 50 Hz Duty: S1

Test Item		Result			
1.	Efficiency %	82.5			
2.	Power Factor	0.721			
3.	Tem. Rise of Stator Winding K	60			
4.	Vibration mm/s				
5.	Noise Lp dB (A) (Lw)				
6.	Breakdown Torque/Rated Torque	2.72			
7.	Pullup Torque/Rated Torque	2.17			
8.	Locked Rotor Tor./Rated Tor.	2.50			
9.	Locked Rotor Cur./Rated Cur.	5.42			
10.	High Voltage Test V	1800			
11.	Hot Insulation Res. of Stator Winding MΩ	300.			
12.	Temperature of Bearing °C	74			
13.	Unbalance of Current %	3.42			
14.	Full Load line Current A	5.338			
15.	Full Load input W	2667			
16.	Full Load torque Nm	22.17			
17.	Max.temp.of enclosure surface °C	71.6			
18.	No Load Current A	3.542			
19.	Slip %	4.994			
20.	Stator Winding phase resistance Ω (95°C)	2.7809			
21.	Stray Load Loss W	28.93			
22.	No Load Stator Power W	183.0			
23.	Core Loss W	77.43			
24.	Friction & Windage Loss W	13.07			
25.	Locked Rotor Power W	12185			
26.	Stator I ii R Loss W	230.1			
27.	Rotor I ii R Loss W	117.8			
28.	Locked Rotor Voltage 100.0V	Current A	4.980	Power W	414.2
Remark:					
75%eff: 83.34 50%eff: 81.79					

Check:

Operator:

Torque - Speed Curve

Type: T2A100L2-6

Output: 2.2 kW

Frequency: 50 Hz

Voltage: 400/230 V

Connection: Y/Δ

