

Type T3A 132S-4

Cod. R132S405,5AW6A60000T

Mounting position

IM	B35
IM	2001

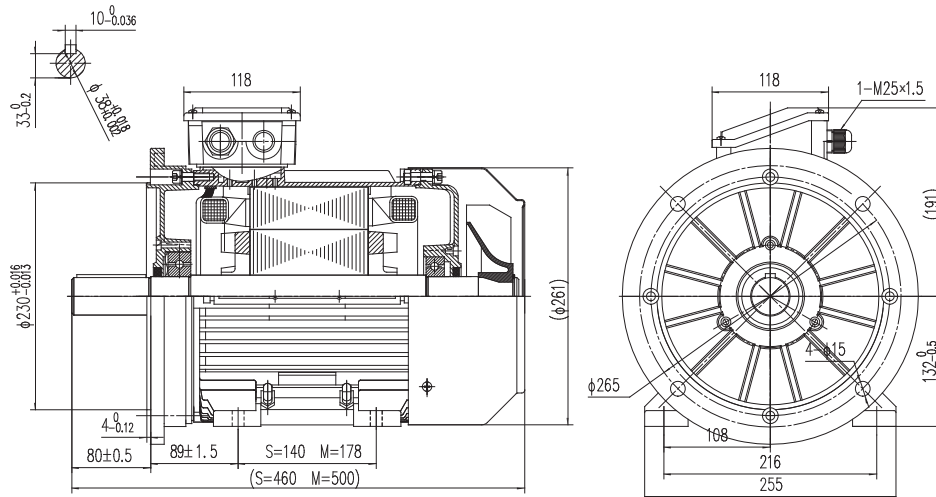

Electrical data			
Rated motor power	5.5		Kw
Rated motor speed	-		min ⁻¹ 50Hz
	1755		min ⁻¹ 60Hz
Rated motor frequency	60		Hz
Rated motor voltage(+/-10%)	-		VΔ/50Hz
	-		VY/50Hz
	208		VΔ/60Hz
Rated motor torque	29.94		Nm (Mn)
	20.31	VΔ/60Hz	A (In)
Rated motor current	11.74	VY/60Hz	A (In)
	9		xIn
Starting motor torque	2.3		xMn
Breakdown motor torque	3.5		xMn
Starting			D.O.L.
Efficiency class	IE3		
Efficiency	50Hz	60Hz	
	-	89.9	100% load
	-	89.3	75% load
	-	88.6	50% load
Power factor cosφ	-	0.84	100% load

General data		
Frame size	132	
Mounting	B35	
Weight	47.3	Kg
Casing material	Aluminum	
Protection	IP	56
Insulation class	H	
Tropicalization	Yes	
Vibration class	A	
Duty	S1	
Direction of rotation	Bidirectional	
Method of cooling	IC	411
Cable entry	2-M25x1,5	
Standards	IEC/DIN/ISO/VDE/EN	
Execute at Standard	IEC 60034-1	
Feet removable	Yes	
Paintwork	7024	C5M marine
Thermal protections	n/a	

Site conditions	
Ambient temperature	from -20°C to +40°C
Altitude above sea level	1000 m

Mechanical data					
Noise level	LpA	63	dB(A)	Bearing DE side	6308-2RS-C3
	LwA	72	dB(A)	Bearing NDE side	6208-2RS-C3
Moment of inertia	0.03446		Kgm ²	Average bearing lifetime	40000 h
Bearings type			NSK	Relubrication interval L1 DE bearing	life h
Lubricants for bearings	See installation and maintenance manual			Relubrication interval L1 NDE bearing	life h
				Compensation ring	NDE SIDE

There may be differences between rating plate and calculated values.

NO LOAD

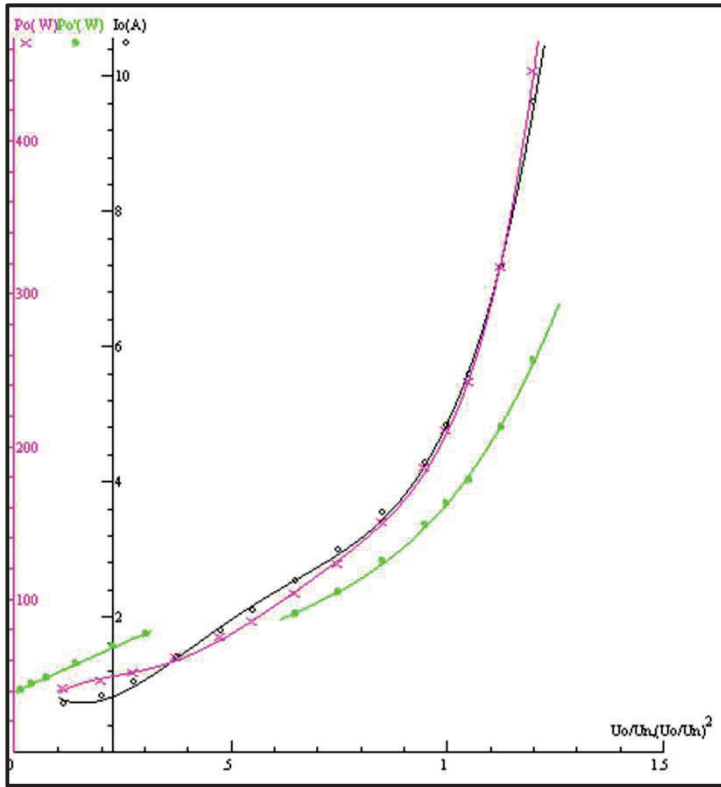

LOCKED ROTOR

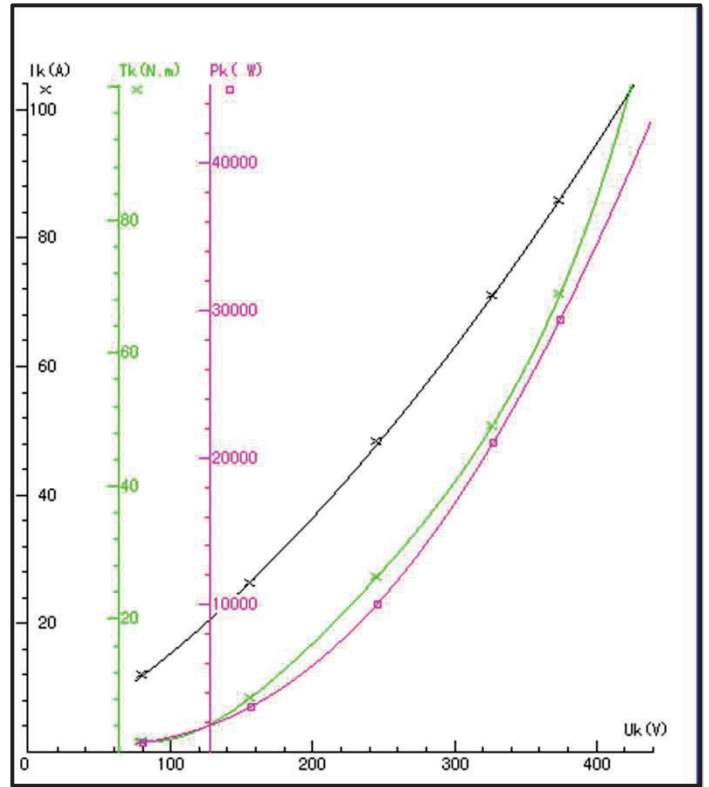

LOAD

