

Type T2A 132S-4

Cod. I132S405,5AB5A0000T

Mounting position

IM	B35
IM	2001

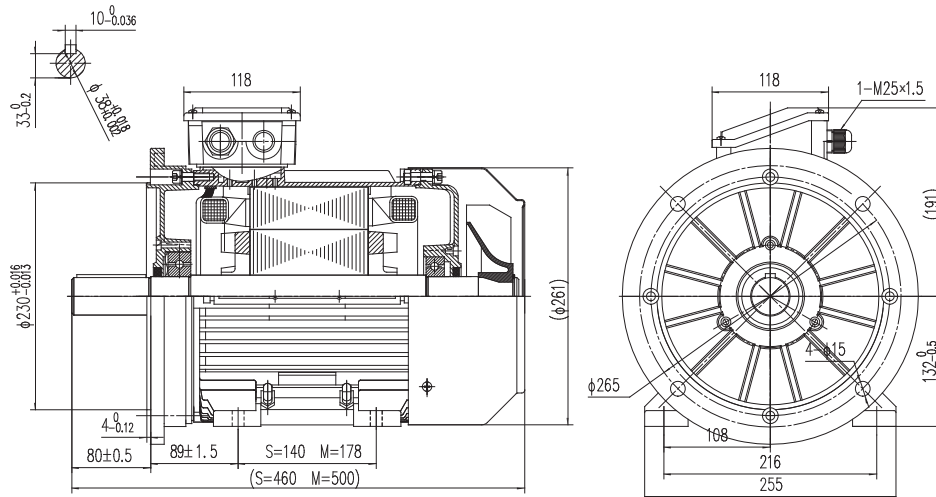

Electrical data			
Rated motor power	5.5		Kw
Rated motor speed	1460		min <sup>-1</sup> 50Hz
	1755		min <sup>-1</sup> 60Hz
Rated motor frequency	50		Hz
Rated motor voltage(+/-10%)	400		VΔ/50Hz
	690		VY/50Hz
	480		VΔ/60Hz
	830		VY/60Hz
Rated motor torque	35.99		Nm (Mn)
Rated motor current	10.9	VΔ/50Hz	A (In)
	6.3	VY/50Hz	A (In)
Starting motor current	8.6		xIn
Starting motor torque	2.1		xMn
Breakdown motor torque	3.5		xMn
Starting			D.O.L.
Efficiency class	IE2		
Efficiency	50Hz	60Hz	
	87.7	89.5	100% load
	88.1	89.1	75% load
	87.0	87.6	50% load
Power factor cosφ	0.83	0.83	100% load

General data		
Frame size	132	
Mounting	B35	
Weight	46.18	Kg
Casing material	Aluminum	
Protection	IP	55
Insulation class	H	
Tropicalization	Yes	
Vibration class	A	
Duty	S1	
Direction of rotation	Bidirectional	
Method of cooling	IC	411
Cable entry	2-M25x1,5	
Standards	IEC/DIN/ISO/VDE/EN	
Execute at Standard	IEC 60034-1	
Feet removable	Yes	
Paintwork	7024	C2 standard
Thermal protections	n/a	

Site conditions	
Ambient temperature	from -20°C to +40°C
Altitude above sea level	1000 m

Mechanical data					
Noise level	LpA	63	dB(A)	Bearing DE side	6308-2RS-C3
	LwA	72	dB(A)	Bearing NDE side	6208-2RS-C3
Moment of inertia	0.03059		Kgm <sup>2</sup>	Average bearing lifetime	40000 h
Bearings type			NSK	Relubrication interval L1 DE bearing	life h
Lubricants for bearings	See installation and maintenance manual			Relubrication interval L1 NDE bearing	life h
				Compensation ring	NDE SIDE

There may be differences between rating plate and calculated values.

Type: T2A132S-4                      Voltage: 400/690 V  
 Output 5,5              KW                      Connection: Δ/Y  
 Frequency: 50              Hz                      Duty: S1

Test Item		Standard		Result	
		Nominal	Tol		
1	Efficiency %			88,08	
2	Power Factor			0,831	
3	Tem. Rise of Stator Winding K			59,9	
4	Vibration mm/s				
5	Noise Lp dB (A) (Lw)				
6	Breakdown Torque/Rated Torque			3,5	
7	Pullup Torque/Rated Torque			1,93	
8	Locked Rotor Tor./Rated Tor.			2,17	
9	Locked Rotor Cur./Rated Cur.			8,56	
10	High Voltage Test V			1800	
11	Hot Insulation Res. of Stator Winding MΩ			300	
12	Temperature of Bearing °C			50	
13	Unbalance of Current %			0,85	
14	Full Load line Current A			10,84	
15	Full-load input power (W)			6244,1	
16	Full Load torque Nm			36,1	
17	Max.temp.of enclosure surface °C			47,8	
18	No Load Current A			5,292	
19	Slip %			2,562	
20	Winding phase resistance 95 °C			2,6462	
21	Stary-load loss (W)			74,553	
22	No-load input power (W)			284	
23	Core loss (W)			146,12	
24	Friction and wind age loss(W)			74,565	
25	Locked Rotor Power (W)			35340	
26	StatorI2Rloss (W)			300,36	
27	RotorI2Rloss (W)			148,54	
28	Locked Rotor Voltage 100 V	Current A	14,77	Power W	1021
50%eff: 88,531                      75%eff: 87,421					

NO LOAD

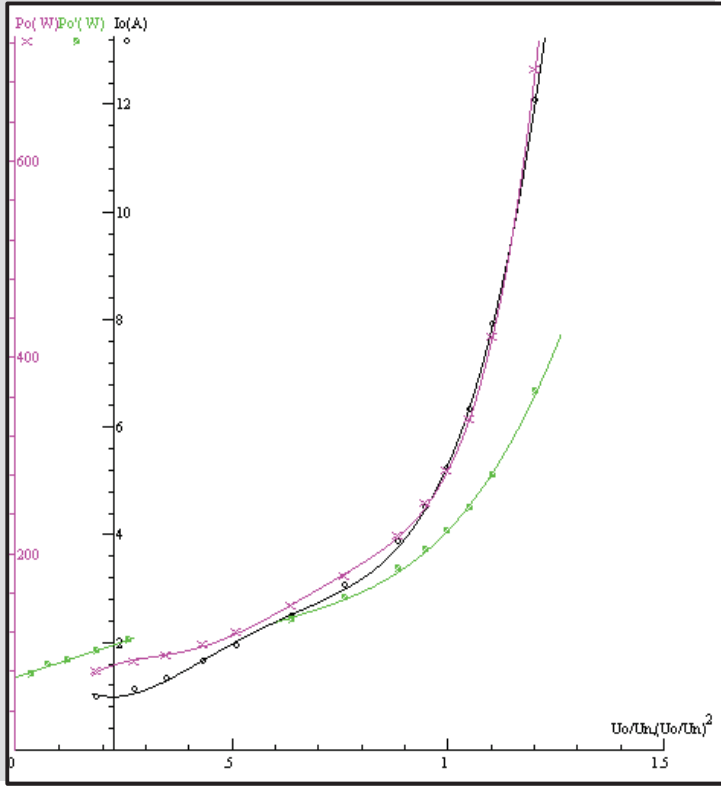

LOCKED ROTOR

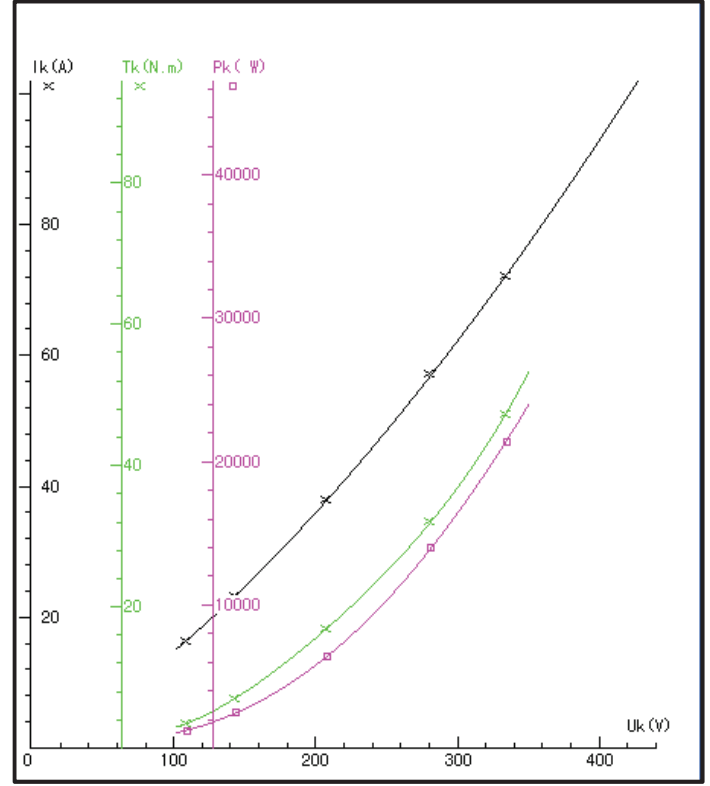

LOAD

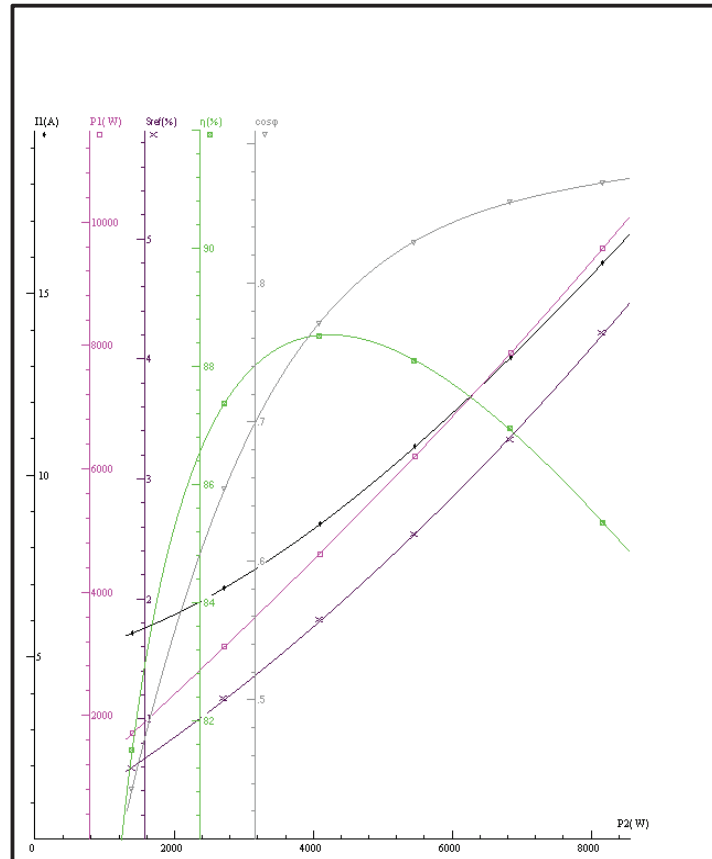

Torque - Speed Curve

