

Type T2A 132S2-2

Cod. I132S207,5AB5A0000T

Mounting position

IM	B35
IM	2001

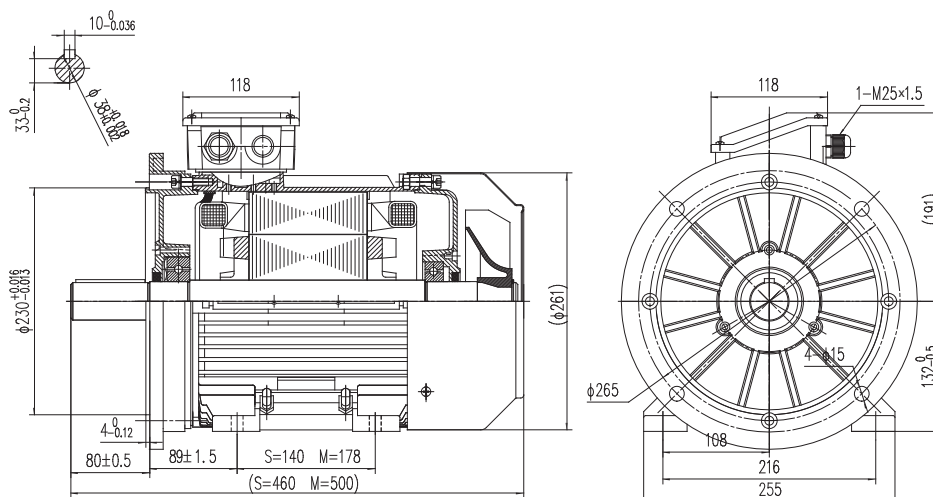

Electrical data			
Rated motor power	7.5		Kw
Rated motor speed	2930		min ⁻¹ 50Hz
	3520		min ⁻¹ 60Hz
Rated motor frequency	50		Hz
Rated motor voltage(+/-10%)	400		VΔ/50Hz
	690		VY/50Hz
	480		VΔ/60Hz
	830		VY/60Hz
Rated motor torque	24.46		Nm (Mn)
Rated motor current	13.5	VΔ/50Hz	A (In)
	7.8	VY/50Hz	A (In)
Starting motor current	10.3		xIn
Starting motor torque	3.1		xMn
Breakdown motor torque	3.7		xMn
Starting			D.O.L.
Efficiency class	IE2		
Efficiency	50Hz	60Hz	
	88.1	90.2	100% load
	88.6	89.8	75% load
	87.9	87.8	50% load
Power factor cosφ	0.91	0.91	100% load

General data		
Frame size	132	
Mounting	B35	
Weight	53.56	Kg
Casing material	Aluminum	
Protection	IP	55
Insulation class	H	
Tropicalization	Yes	
Vibration class	A	
Duty	S1	
Direction of rotation	Bidirectional	
Method of cooling	IC	411
Cable entry	2-M25x1,5	
Standards	IEC/DIN/ISO/VDE/EN	
Execute at Standard	IEC 60034-1	
Feet removable	Yes	
Paintwork	7024	C2 standard
Thermal protections	n/a	

Site conditions	
Ambient temperature	from -20°C to +40°C
Altitude above sea level	1000 m

Mechanical data					
Noise level	LpA	69	dB(A)	Bearing DE side	6308-2RS-C3
	LwA	78	dB(A)	Bearing NDE side	6208-2RS-C3
Moment of inertia	0.01647		Kgm ²	Average bearing lifetime	40000 h
Bearings type			NSK	Relubrication interval L1 DE bearing	life h
Lubricants for bearings	See installation and maintenance manual			Relubrication interval L1 NDE bearing	life h
				Compensation ring	NDE SIDE

There may be differences between rating plate and calculated values.

NO LOAD

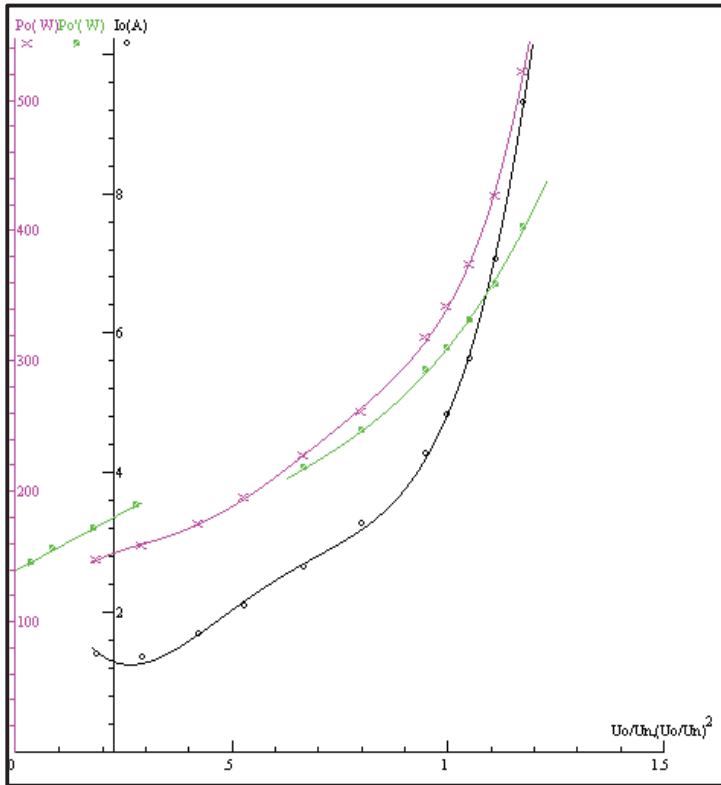

LOCKED ROTOR

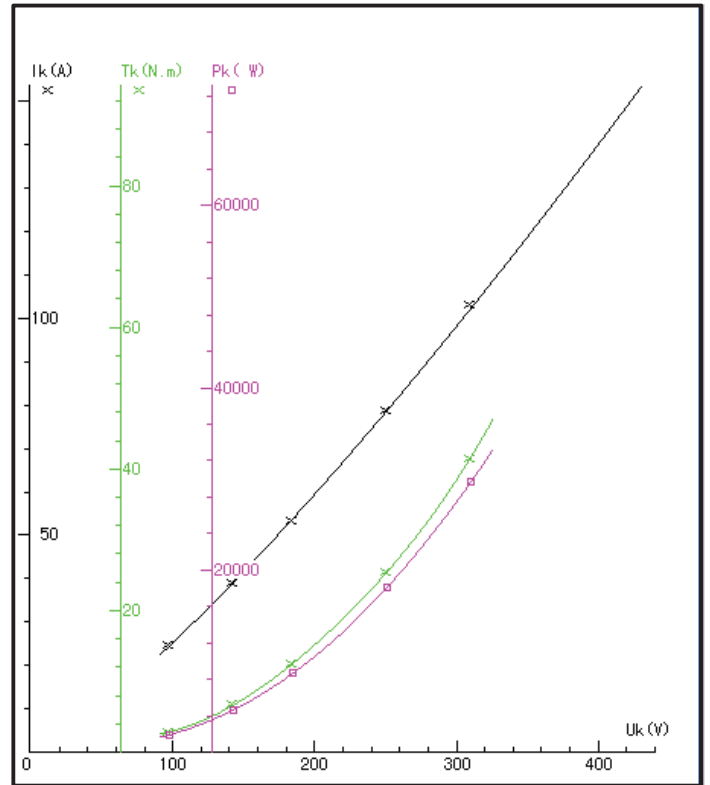

LOAD

