



QC.3.2...

OVERALL DIMENSIONS

CH. III PAGE 4

QC.3.2... 2 WAY COMPENSATED FLOW RATE REGULATORS

These QC.3.2... compensated flow rate regulators are designed to control and maintain a constant irrespective of the pressure variations upstream and downstream of the regulation section. Their new cast construction has made it possible to obtain a wider flow rate range, taking the upper limit to 35 l/min (4 turns version) while maintaining unchanged the pressure differential required to obtain good pressure compensation.

All models are available with and without reverse flow check valve, complete with an "anti-jump" device on request. This accessory has been designed to eliminate the problem which manifests itself as a "anti-jump" in the controlled actuator due to the instantaneous flow rate variation that takes place under the form of a transient every time the flow is made to pass through the regulator.

Max. operating pressure	320 bar
Opening pressure (with bypass)	1 bar
Min. regulated flow rate (Q1 version)	0.03 ÷ 0.05 l/min
Nominal regulated flow rate (1 turn version)	1,5 ÷ 30 l/min
Nominal regulated flow rate (4 turns version)	1,5 ÷ 35 l/min
Difference in pressure (Δp) for vers. Q1	3 bar
Difference in pressure (Δp) Q2-Q3-Q4-Q5-Q6	8 bar
Hydraulic fluids	Mineral oils DIN 51524
Fluid viscosity	10 ÷ 500 mm ² /s
Fluid temperature	-25°C ÷ 75°C
Ambient temperature	-25°C ÷ 60°C
Max. contamination level(*) class 10 in accordance with NAS 1638 with filter $\beta_{25} \geq 75$	
Dependency on temperature (Q1 vers.)	5%
Dependency on temperature (Q2 vers.)	3%
Dependency on temperature (Q3-Q4-Q5-Q6)	2%
Weight	1,5 Kg

(*) Max contamination level must be respect to obtain the right function of the valve

ORDERING CODE

QC Compensated flow rate regulated

3 CETOP 3/NG6

2 2 way

G Anti-jump system with internal check valve (omit if not required)

****** Nominal flow rate ranges
1 Turn version **4 Turn version**
Q1 = 1,5 l/min **Q1** = 1,5 l/min
Q2 = 3 l/min **Q2** = 4 l/min
Q3 = 9 l/min **Q3** = 10 l/min
Q4 = 19 l/min **Q4** = 21 l/min
Q5 = 24 l/min **Q5** = 28 l/min
Q6 = 30 l/min **Q6** = 35 l/min

K Version with lock (omit if not required)

***** **1** = 1 turn version
4 = 4 turns version

R With internal check valve (omit if not required)

****** **00** = No variant
V1 = Viton

5 Serial No.

HYDRAULIC SYMBOLS

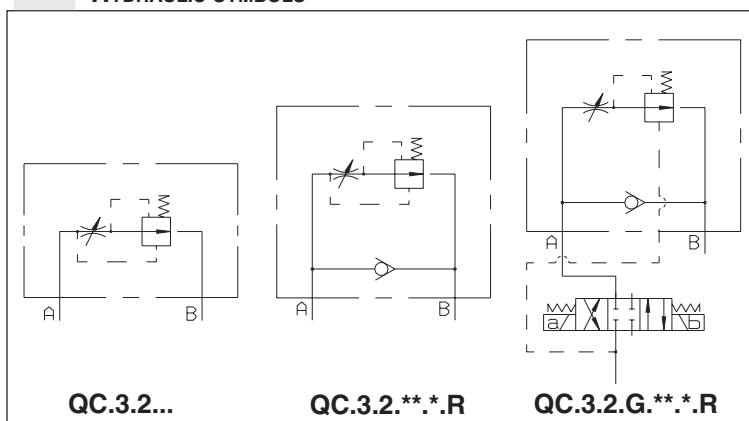

DIAGRAMS

REGULATED FLOW RATE
1 TURN VERSION

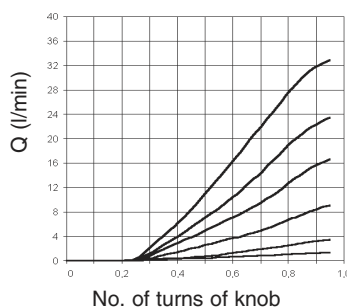

REGULATED FLOW RATE
4 TURNS VERSION

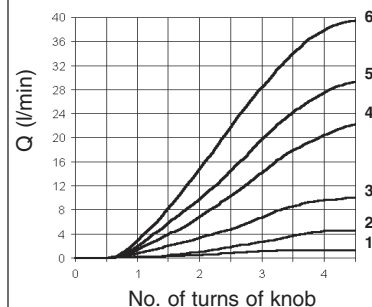

FLOW RATE - INLET PRESSURE

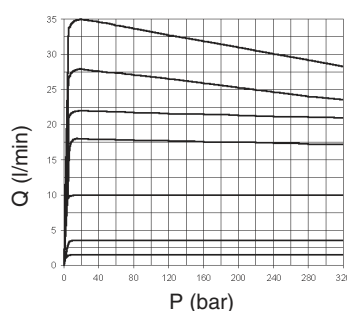

FREE FLOW THROUGH
CHECK VALVE

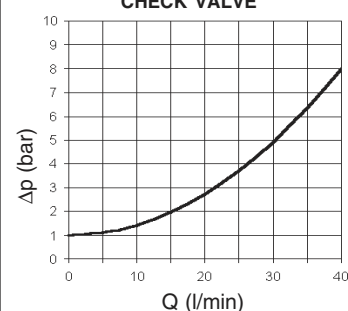

QC.3.3... 3 WAY COMPENSATED FLOW RATE REGULATORS



QC.3.3...

OVERALL DIMENSIONS	CH. III PAGE 4
AM.3.ABU...	CH. III PAGE 4

This regulator type can be used whenever it is necessary to obtain a constant fluid flow irrespective of the pressure variations present upstream or downstream. It is fitted with a third T line for discharging any excessive flow rate.

When the reverse flow check valve is needed, the check valve holder type "AM.3.ABU.3..." can be fitted underneath the valve. (The check valve holder must be ordered separately see page III•4)

Max. operating pressure	320 bar
Opening pressure (with bypass)	1 bar
Min. regulated flow rate (Q1 version)	0.03 ÷ 0.05 l/min
Nominal regulated flow rate	1 ÷ 22 l/min
Difference in pressure (Δp) for vers. Q1	3 bar
Difference in pressure (Δp) Q2-Q3-Q4-Q5-Q6	8 bar
Hydraulic fluids	Mineral oils DIN 51524
Fluid viscosity	10 ÷ 500 mm ² /s
Fluid temperature	-25°C ÷ 75°C
Ambient temperature	-25°C ÷ 60°C
Max. contamination level(*) class 10 in accordance with NAS 1638 with filter $\beta_{25} \geq 75$	
Dependency on temperature (Q1 vers.)	5%
Dependency on temperature (Q2 vers.)	3%
Dependency on temperature (Q3-Q4-Q5)	2%
Weight	1,5 Kg
(*) Max contamination level must be respect to obtain the right function of the valve	

ORDERING CODE

QC	Compensated flow rate regulator
3	CETOP 3/NG6
3	3 way
**	Flow rate ranges Q1 = 1 l/min Q2 = 3 l/min Q3 = 9 l/min Q4 = 17 l/min Q5 = 24 l/min
K	Version with lock (omit if not required)
*	1 = 1 turn version 4 = 4 turns version
**	00 = No variant V1 = Viton
3	Serial No.

HYDRAULIC SYMBOLS

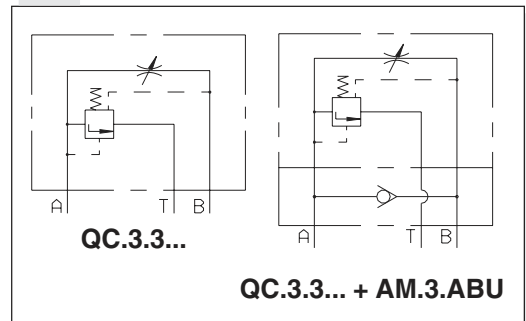

DIAGRAMS

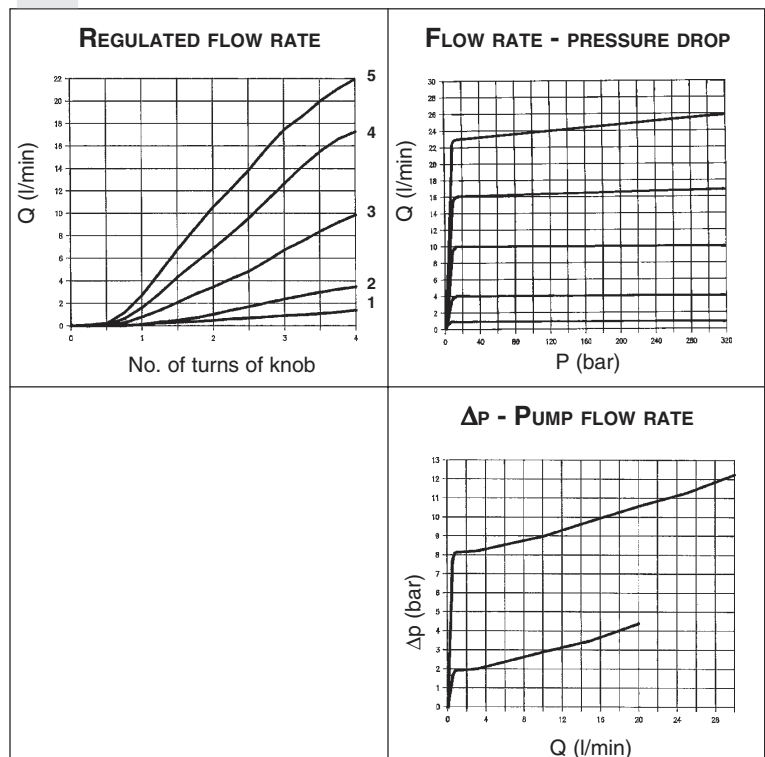

QC.3.2... 2 WAY FLOW RATE REGULATOR

QC.3.3... 3 WAY FLOW RATE REGULATOR

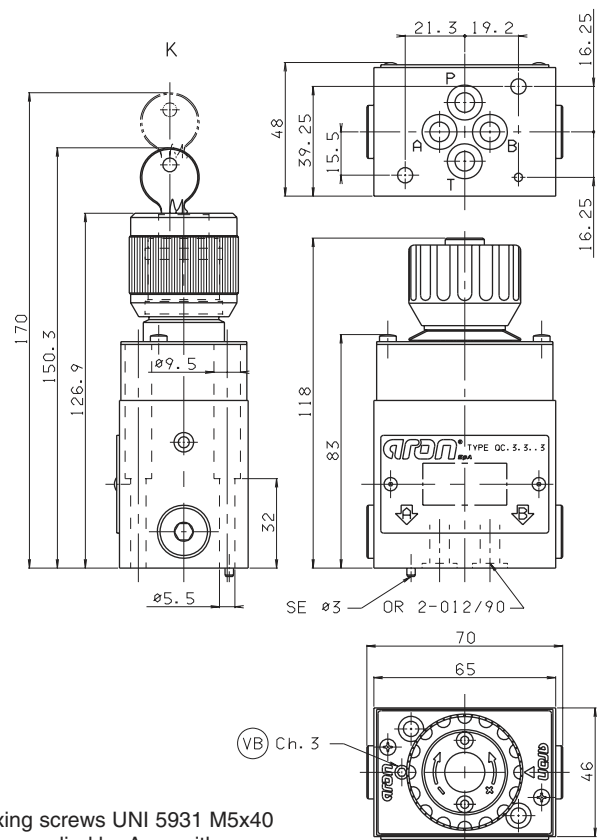
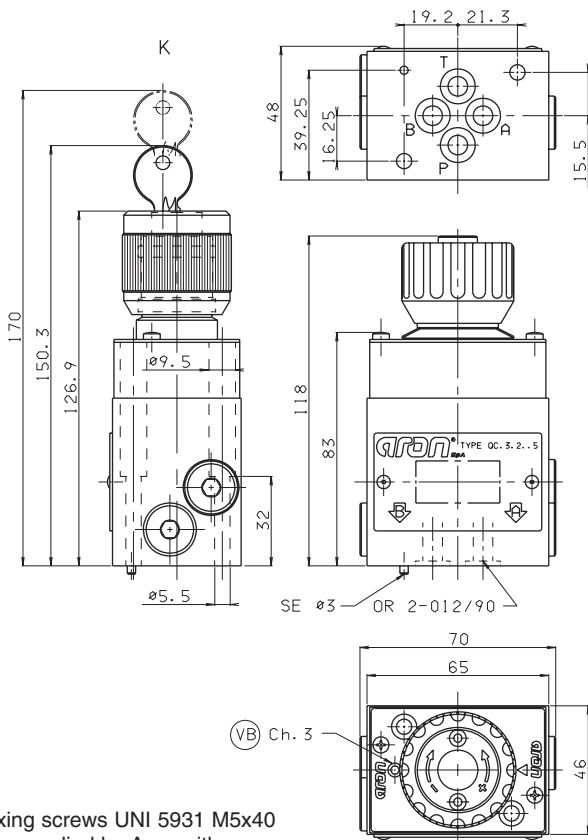

Fixing screws UNI 5931 M5x40 are supplied by Aron with material specifications min. 8.8 Tightening torque 5 Nm / 0.5 Kgm

Fixing screws UNI 5931 M5x40 are supplied by Aron with material specifications min. 8.8 Tightening torque 5 Nm / 0.5 Kgm

File: ETQC3S00S

00/2000/e

AM.3.ABU... CHECK VALVE HOLDER FOR REGULATORS TYPE QC.3...



This check valve holder must be fitted underneath the QC valve when the reverse flow function is needed.

ORDERING CODE

- AM** Modulating valve
- 3** CETOP 3/NG06
- ABU** External check valve for QC.3.*.
- 3** For 2 way and 3 way
- 00** No variant
- 1** Serial No.

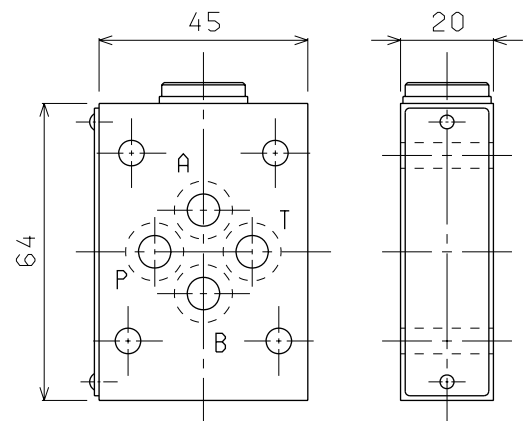

Weight: 0,4 Kg
Fixing screws for regulator and modular check valve M5x60 UNI 5931 - 12K