

DIRECTIONAL CONTROL VALVES OTHER OPERATOR CETOP 3/NG6



1



OTHER OPERATOR

STANDARD SPOOLS	CH. I PAGE 10
AD.3.P...	CH. I PAGE 16
AD.3.O...	CH. I PAGE 16
AD.3.M...	CH. I PAGE 17
AD.3.D...	CH. I PAGE 17

INTRODUCTION

The ARON directional control valves NG6 are designed for subplate mounting with an interface in accordance with UNI ISO 4401 - 03 - 02 - 0 - 94 standard (ex CETOP R 35 H 4.2-4-03), and can be used in all fields on account of their high flow rate and pressure capacities combined with compact overall dimensions.

The use of solenoids with wet armatures allows a very practical, safe construction completely dispensing with dynamic seals; the solenoid tube is screwed directly onto the valve chest whilst the coil is kept in position by means of a lock nut.

The special, precise construction of the ports and the improvement of the spools enables relatively high flow rates to be accommodated with a minimal pressure drop (Δp).

The centre position is obtained by means of calibrated length springs which reposition the spool in the centre or end of travel position once the action of the impulse is over.

The valves are designed for use with DIN 51524 standard hydraulic mineral oils and it is recommended that filters should be fitted to ensure a maximum contamination level of class 10 in accordance with NAS 1638, $\beta_{25} \geq 75$.

ORDERING CODE

- AD** Directional valve
- 3** CETOP 3/NG06
- *** Type of operator
P = Pneumatic
O = Oleodynamic
M = Mechanically
D = Direct mechanically
 (For other operator see past pages)
- **** Spool (see page I•10)
- *** Mounting type (tab.1)
- Z** No voltage
- **** Variants:
00 = no variant
V1 = Viton
H1 = Marine version (for AD3P only)
DI(*) = Internal draining (for AD3O only)
- 2** Serial No.

TAB.1 MOUNTING

STANDARD	
C	
D	
E	
F	
SPECIALS (WITH PRICE INCREASING)	
G	
H	
I	
L	
M	

• In case of **mounting D** with detent a maximum supply time of 2 sec is needed (only for AC coils).

(*) The DI variant is recommended in the environments characterised by the presence of dust or any type of contamination.

PRESSURE DROPS

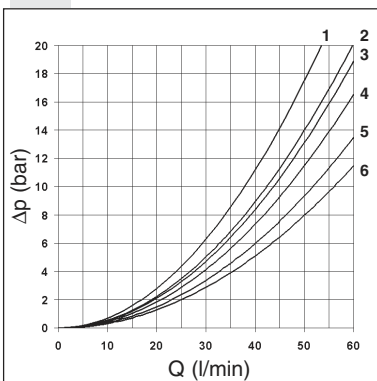

Spool type	Connections				
	P→A	P→B	A→T	B→T	P→T
01	5	5	5	5	
02	6	6	6	6	5
03	5	5	6	6	
04	1	1	2	2	4
05	5	5	5	5	
06	5	5	6	5	
07	5	5	5	6	
08	6	6			
09	5	5		5	
10	5	5	5	5	

Curve No.

Spool type	Connections				
	P→A	P→B	A→T	B→T	P→T
11	4			6	
22		4	6		
12		5		6	
13		5	6	6	
14	2	1	1	1	2
28	1	2	1	1	2
15 - 19	4	4	6	6	
16	5	5	4	4	
17 - 21	1	3			
18	5	5			
20	4	4	4	4	

Curve No.

The diagram at the side shows the pressure drop curves for spools during normal usage. The fluid used is a mineral oil with a viscosity of 46 mm²/s at 40°C; the tests have been carried out at a fluid temperature of 40°C. For higher flow rates than those in the diagram, the losses will be those expressed by the following formula:

$$\Delta p_1 = \Delta p \times (Q_1/Q)^2$$

where Δp will be the value for the losses for a specific flow rate Q which can be obtained from the diagram, Δp_1 will be the value of the losses for the flow rate Q1 that is used.

AD.3.P... PNEUMATIC OPERATION TYPE VALVES CETOP 3/NG6



1

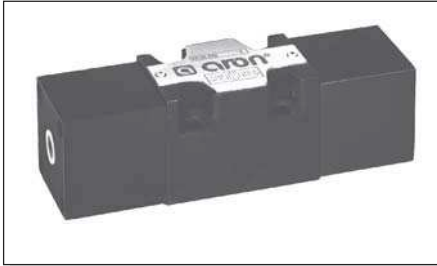

Max. pressure ports P/A/B	320 bar
Max. pressure port T	160 bar
Max. flow	60 l/min
Minimum operating pressure	2 + [0.027 x (pt*)] bar - see note
Maximum operating pressure	20 bar
Fluid viscosity	10 ÷ 500 mm ² /s
Fluid temperature	-25°C ÷ 75°C
Ambient temperature	-25°C ÷ 60°C
Max. contamination level	class 10 in accordance with NAS 1638 with filter β ₂₅ ≥ 75
Weight single pilot	1,2 Kg
Weight twin pilot	1,8 Kg

• Possible mountings:
C/D/E/F/G/H/I L/M

Ordering code see page before

(pt*) = pressure at port T

OVERALL DIMENSIONS

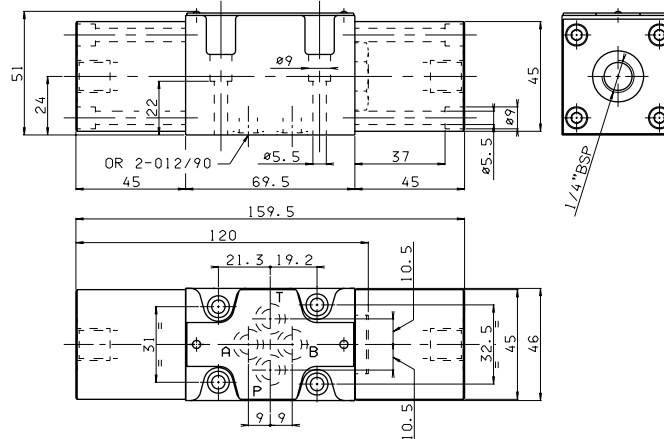

Fixing screws UNI 5931 M5x30
with material specifications min. 8.8
Tightening torque 5 Nm / 0.5 Kgm

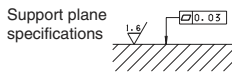

IAD3P - 02/2000/e

AD.3.O... OLEODYNAMIC OPERATION TYPE VALVES CETOP 3/NG6

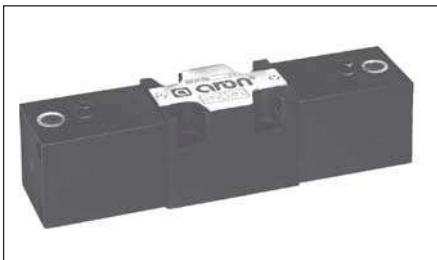

Max. pressure ports P/A/B	320 bar
Max. pressure port T	160 bar
Max. flow	60 l/min
Minimum operating pressure	15 + [0.1 x (pt*)] bar - see note
Maximum operating pressure	250 bar
Fluid viscosity	10 ÷ 500 mm ² /s
Fluid temperature	0°C ÷ 75°C
Ambient temperature	-25°C ÷ 60°C
Max. contamination level	class 10 in accordance with NAS 1638 with filter β ₂₅ ≥ 75
Weight single pilot	1,5 Kg
Weight twin pilot	2,3 Kg

• Possible mountings:
C/D/E/F/G/H/I L/M

Ordering code see page before

(pt*) = pressure at port T

The DI variant is recommended in the environments characterised by the presence of dust or any type of contamination.

Further technical specifications (for DI variant only)

Minimum operating pressure	[10 + (pt*)] bar - see note
Maximum operating pressure	250 bar
Max. piloting leakage	1 l/min

OVERALL DIMENSIONS

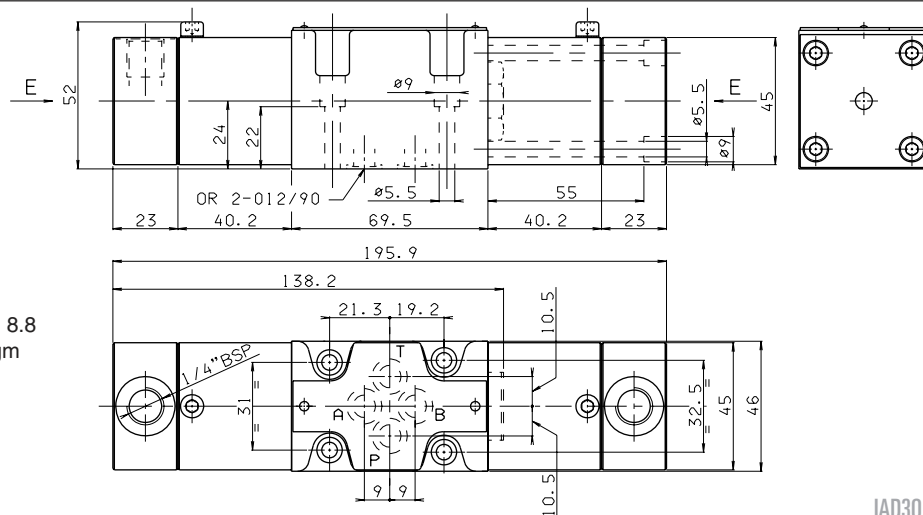

E = Manual override

Fixing screws UNI 5931 M5x30
with material specifications min. 8.8
Tightening torque 5 Nm / 0.5 Kgm

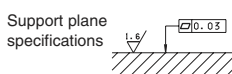

IAD3O - 03/2000/e

AD.3.M... MECHANICALLY OPERATED TYPE VALVES CETOP 3/NG6



1

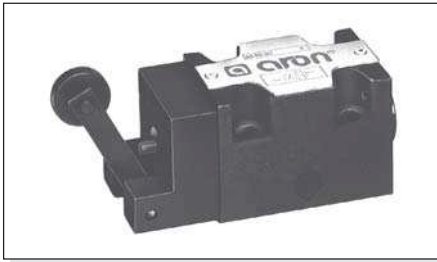

Max. pressure ports P/A/B	320 bar
Max. pressure port T	160 bar
Max. flow	60 l/min
Minimum operating force - see note (*)	2,5 Kg
Maximum operating force - see note (**)	13 Kg
Cam angle	27°
Fluid viscosity	10 ÷ 500 mm ² /s
Fluid temperature	-25°C ÷ 75°C
Ambient temperature	-25°C ÷ 60°C
Max. contamination level	class 10 in accordance with NAS 1638 with filter $\beta_{25} \geq 75$
Weight	1 Kg

- Possible mountings: E / F / G / H
- Ordering code see page before
- Note: (*) In the absence of counter-pressure at port T
- (**) with a pressure of 160 bar at port T

OVERALL DIMENSIONS

Stroke 12,4 mm
Working stroke 3 mm

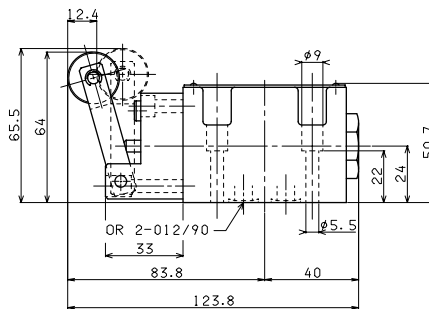

Fixing screws UNI 5931 M5x30 with material specifications min. 8.8
Tightening torque 5 Nm / 0.5 Kgm

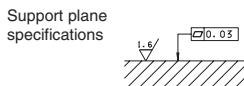

EAD3M - 02/2000/e

AD.3.D... DIRECT MECHANICALLY OPERATED TYPE VALVES CETOP 3/NG6



Max. pressure ports P/A/B	320 bar
Max. pressure port T	20 bar
Max. flow	60 l/min
Operating force - see note (*)	6 Kg
Fluid viscosity	10 ÷ 500 mm ² /s
Fluid temperature	0°C ÷ 75°C
Ambient temperature	-25°C ÷ 60°C
Max. contamination level	class 10 in accordance with NAS 1638 with filter $\beta_{25} \geq 75$
Weight	1,5 Kg

- Possible mountings: E / F / G / H
- Ordering code see page before
- Note: (*) In absence of counter-pressure at port T

OVERALL DIMENSIONS

Stroke 6 mm
Extra stroke 2 mm
Working stroke 3 mm

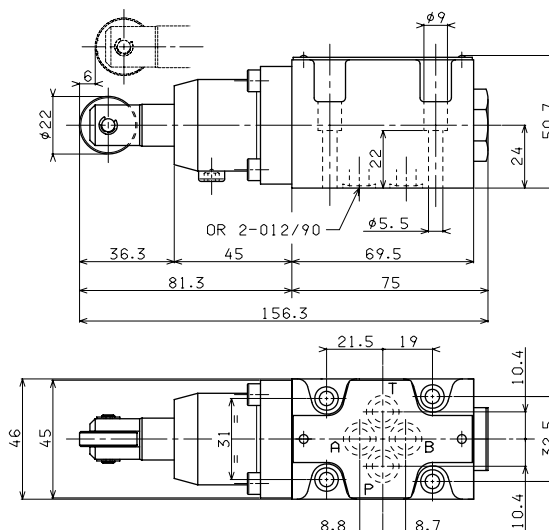

Fixing screws UNI 5931 M5x30 with material specifications min. 8.8
Tightening torque 5 Nm / 0.5 Kgm

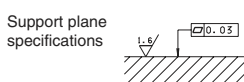

EAD3D - 02/2000/e