

REM.S.RA... TYPE ELECTRONIC REGULATORS FOR SINGLE SOLENOID PROPORTIONAL CONTROL VALVES

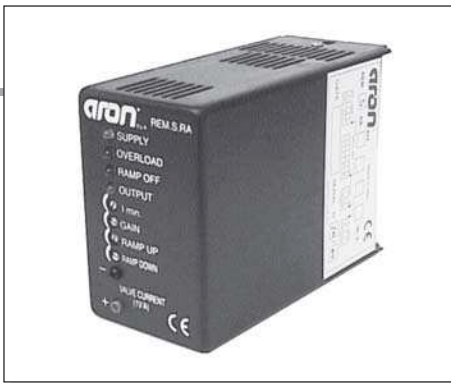

REM.S.RA...

CALIBRATION PROCEDURE	CH. IX PAGE 5
OVERALL DIMENSIONS	CH. IX PAGE 10
MOUNTING BASES	CH. IX PAGE 10

ORDERING CODE

REM	Miniaturized electronic regulator in Octal type container
S	Single solenoid
RA	Asymmetrical ramp
*	Maximum output current I_{MAX} (A) X = 0.88 A Y = 1.76 A Z = 2.8 A
*	Input reference (V) see note (*) below 2 = 0 ÷ + 2 V 5 = 0 ÷ + 5 V 0 = 0 ÷ + 10 V A = 0 ÷ 20 mA
*	Frequency Dither 1 = 100 Hz (standard) 2 = 330 Hz (for XP.3)
*	Minimum initial current G = step (normally for XD.* and XDP.3 valves) C = continuous (normally for XP.3, XQ.3, XQP.* and CXQ.3 valves)
00	No variant
4	Serial No.

(* If the input reference is a current signal (mA) the regulator has to be pre-setted in the factory.

• **CE** registered mark for industrial environment with reference to the electromagnetic compatibility. European norms:

- EN61000-6-2 general safety norm - industrial environment
- EN61000-6-4 emission general norm - residential environment

• Product in accordance with **RoHS 2002/95/CE** Europe Directive.

The electronic control card type REM.S.RA has been designed to drive the "XD.*A, XDP.3.A, XP.3, XQ.3, XQP.* and CXQ.3" series ARON single solenoid proportional valves without integral position transducer. The control card is enclosed in an "OCTAL" type housing, a typical relay mounting standard. The output stage operates on the pulse width modulation principle (P.W.M.) and is provided with current feedback in order to obtain a solenoid output current proportional to the reference input signal. Output short circuit and supply polarity inversion protection is provided.

Gain, minimum current and rise and fall ramp time adjustments are possible through the corresponding front panel trimming potentiometers, while the output current to the solenoid can be measured via the Valve Current test points, and the ramp operation can be excluded.

The product incorporates a serial interface for adjustment of parameters.

Pay attention please: electronic regulators must be used in dampness and water protected places.

ADJUSTMENT PANEL

Supply	10VDC ÷ 30VDC (green led)
Overload	Protection against overload (red led)
Ramp off	Ramp off (red led)
Output	Output (current at solenoid, yellow led)
I. min.	Minimum current adjustment
Gain	Gain adjustment
Ramp up	Rump up adjustment time
Ramp down	Rump down adjustment time
Valve Current	Current test point at solenoid (1V=1A)

ADJUSTMENT PANEL

Supply: 10VDC ÷ 30VDC (green led)
 Overload: Protection against overload (red led)
 Ramp off: Ramp off (red led)
 Output: Output (current at solenoid, yellow led)
 I. min.: Minimum current adjustment
 Gain: Gain adjustment
 Ramp up: Rump up adjustment time
 Ramp down: Rump down adjustment time
 Valve Current: Current test point at solenoid (1V=1A)

If any field is missing from the ordering code the standard setting is as follows:

- Input ref. = 0 ÷ 5V
- Dither 100Hz
- I_{min} = continuous
- I_{max} = 0.8A

ELECTRICAL CIRCUIT AND CONNECTIONS

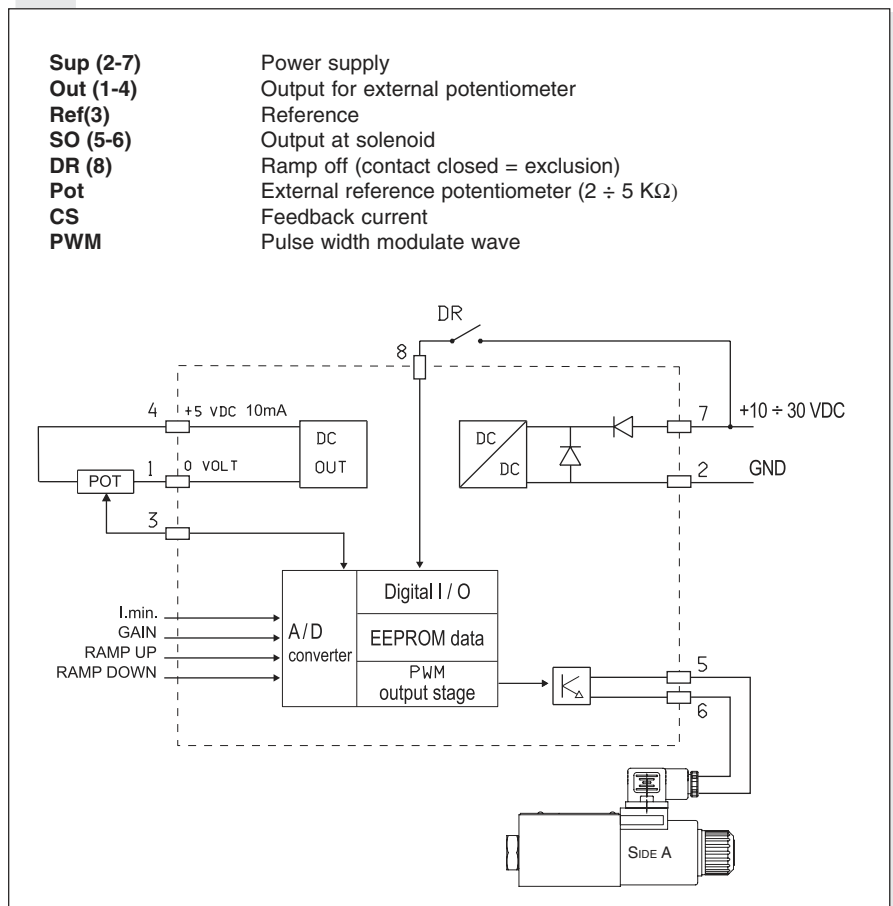

Power supply	10 ÷ 30 VDC
Maximum supply voltage	36 V
Power absorption	40 W
Current output setting by dip switches	$I_{max} = 2.8A$ $I_{max} = 1.76A$ $I_{max} = 0.88A$
External potentiometer supply output short circuit protected	+5V 10mA
Reference input signal setting by dip switches	0 ÷ +2V 0 ÷ +5V 0 ÷ +10V
Note: for the current signal (mA) the regulator has to be pre-setted in the factory.	0 ÷ 20mA
Polarization current adjustment	$I_{min} = 0 \div 50\% I_{max}$
Current gain adjustment	50% ÷ 100% I_{max}
Ramp time adjustment	0 ÷ 20 sec
Ambient operating temperature	-20 ÷ +70°C
Current test point	1 Volt = 1 Ampere
Weight	0,101 Kg

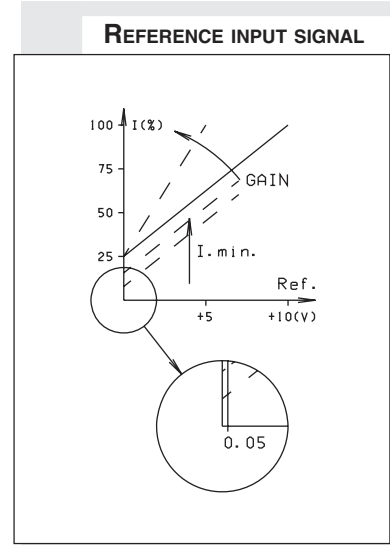

REM.S.RA... INSTRUCTIONS FOR USE

CALIBRATION PROCEDURE

Connect the card in the proper way following the previous page diagram but without powering it or in the way following the next page "Typical connections". Turn completely anticlockwise (20 turns about) the trimming potentiometers of Minimu Current (I_{min}) and Ramp Time (Ramp-up and Ramp-down), and position the reference potentiometer on zero. Before powering the card, ensure that any unforeseen hydraulic system movement cannot cause material damage or injury to people. Power now the card; the green LED should light up.

MINIMUM CURRENT OR POLARIZATION CURRENT ADJUSTMENT

Turn slowly the minimum current trimming potentiometer clockwise (I_{min}) until an actuator movement can be visually detected. Turn slowly anticlockwise the potentiometer: the minimum current setting will be adjusted correctly when the actuator movement stops. For the REM model with minimum initial threshold current, set the reference signal to a V_{ref} of 150 mV.

MAXIMUM CURRENT GAIN ADJUSTMENT

Turn first the ramp time trimming potentiometers clockwise by at least 10 turns, if the system could be damaged by a too fast solenoid operation (evaluate the application carefully). The maximum actuator speed can now be adjusted. Turn the reference signal to its maximum setting and rotate slowly the GAIN trimming potentiometer (GAIN) until the maximum required speed is obtained. The speed can now be varied by moving the potentiometer.

RAMP TIME ADJUSTMENT (RAMP-UP E RAMP-DOWN)

The ramp time is the time taken to pass from the minimum to the maximum current value, and vice versa. It's adjustable from a minimum of 0s up to a maximum of 20s (to reach the maximum current value setted). Turning clockwise the trimming potentiometer, the ramp time increases.

NOTES:

- The ramp fall time affects the actuator stop position. Moving the reference to zero Volt, the actuator goes on moving till the setted ramp time is elapsed. Therefore it's necessary to adjust it properly.
- When the overload red LED lights up, it will be necessary to switch off the power to the card, switching it on again after having eliminated the cause of overload.

REM.S.RA... DIP SWITCHES TABLE

For our proportional valves are recommended the following settings:

G	XD.3.A	DITHER =100Hz	$I_{max.} = 2.35A$ with 9V coil
G	XDP.3.A	DITHER =100Hz	$I_{max.} = 2.35A$ with 9V coil
C	XQ.3	DITHER =100Hz	$I_{max.} = 2.35A$ with 9V coil
C	XQP.3	DITHER =100Hz	$I_{max.} = 2.35A$ with 9V coil
C	CXQ.3	DITHER =100Hz	$I_{max.} = 2.35A$ with 9V coil
G	XD.3.A	DITHER =100Hz	$I_{max.} = 1.76A$ with 12V coil
G	XDP.5.A	DITHER =100Hz	$I_{max.} = 2.5A$ with 12V coil
G	XDP.3.A	DITHER =100Hz	$I_{max.} = 1.76A$ with 12V coil
C	XQ.3	DITHER =100Hz	$I_{max.} = 1.76A$ with 12V coil
C	XQP.3	DITHER =100Hz	$I_{max.} = 1.76A$ with 12V coil
C	XQP.5	DITHER =100Hz	$I_{max.} = 2.5A$ with 12V coil
C	XP.3	DITHER =330Hz	$I_{max.} = 1.25A$ with 12V coil
C	CXQ.3	DITHER =100Hz	$I_{max.} = 1.76A$ with 12V coil
G	XD.3.A	DITHER =100Hz	$I_{max.} = 0.88A$ with 24V coil
G	XDP.5.A	DITHER =100Hz	$I_{max.} = 1.25A$ with 24V coil
G	XDP.3.A	DITHER =100Hz	$I_{max.} = 0.88A$ with 24V coil
C	XQ.3	DITHER =100Hz	$I_{max.} = 0.88A$ with 24V coil
C	XQP.3	DITHER =100Hz	$I_{max.} = 0.88A$ with 24V coil
C	XQP.5	DITHER =100Hz	$I_{max.} = 1.25A$ with 24V coil
C	XP.3	DITHER =330Hz	$I_{max.} = 0.68A$ with 24V coil
C	CXQ.3	DITHER =100Hz	$I_{max.} = 0.88A$ with 24V coil

Six miniature switches are mounted internally on one of the REM sides. The REM configuration to suit any particular application can be implemented by setting these switches.

PWM frequency (100 to 330 Hz), minimum (continuous or step) current, reference voltage range and maximum current (I_{max}) can thus be adjusted.

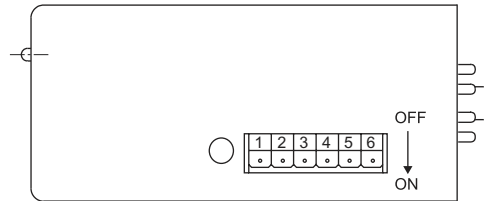

Function DIP sw	DITHER (Hz)		I min.		Input ref. (Volt)				I.max. (A)		
	100	330	C	G	0 ÷ 10	0 ÷ 5	0 ÷ 2	0 ÷ 20mA	2.8	1.76	0.88
1	OFF	ON									
2			OFF	ON							
3					OFF	ON	OFF	ON			
4					OFF	OFF	ON	OFF			
5									OFF	ON	OFF
6									OFF	OFF	ON

TYPICAL CONNECTIONS

9

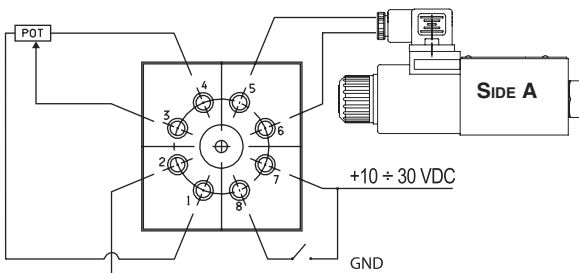

REFERENCE INPUT SIGNAL

Input Ref.: 0V ÷ +2V 0V ÷ +5V
0V ÷ +10V

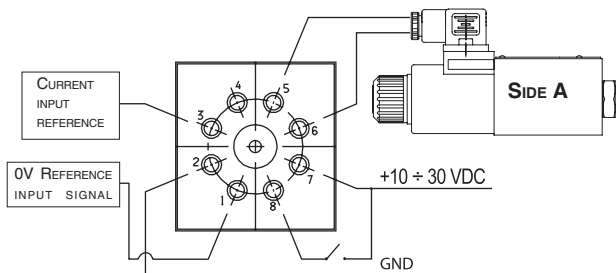

**EXTERNAL REFERENCE INPUT SIGNAL VALUE GENERATOR
OR IN CASE OF CURRENT INPUT REFERENCE**

- The connection between REM and the solenoid must be direct
- The common one of return to proportional solenoid must not be shared between other valve connections or electrical equipment worker.

POT = 1000 ÷ 5000 Ω

Incorrect use of the products described in this catalogue may cause harm to personnel and equipment. The technical information given for each product in this catalogue may be subject to variation, and the manufacturer reserves the right to make constructional modifications without giving prior notice. Each product presented, its data, features and technical specifications must therefore be examined and checked by members of the user's staff (possessing suitable technical knowledge) taking into consideration the intended use of product. The user must, in particular, assess the operating conditions of each product in relation to the application that he intends to use it for, analysing the data, features and technical specifications in view of the proposed applications, and ensuring that, in use in the product, all of the conditions relating to the safety of personnel and equipment, also in the event of breakdown, are respected.