



XDP.5.A... / XDP.5.C ...

PROPORTIONAL DIRECTIONAL VALVES OPEN LOOP



The open loop valves of series XDP control the direction and the volume of the flow according to the feeding current to the proportional solenoid.

Each Δp variation on the valve leads to the variation of the capacity which has been set, anyway the valve guarantees an high inner compensation grade and limits the adjustment capacity.

For a more accurate capacity control, 2 or 3-way hydrostats for modular plate design are available (see note below in ordering code). The shown flow rates are typical for one line operation (e.g. from P to B).

Q5 variant - This variant that consists of a solenoid chamber drainage separated from the T line and obtained on CETOP RO5 interface allows operation with up to 320 bar max. back pressure on the T line. To ensure maximum solenoid valve mounting safety and supplementary drainage, only 12.9 material fixing screws must be used with it.

XDP.5...

"D19P" PROPORT. SOLENOIDS CH. VIII PAGE 7

REM.S.RA... CH. IX PAGE 4

REM.D.RA... CH. IX PAGE 7

AM.5.H... CH. VIII PAGE 11

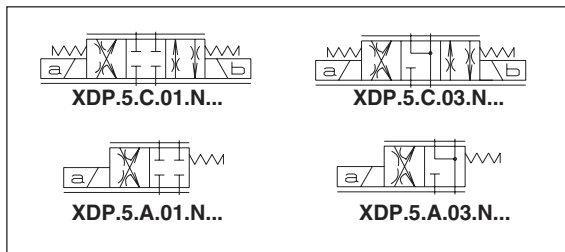

ORDERING CODE

XDP

Open loop proportional directional valve

5

CETOP 5/NG10

A = Single solenoid
C = Double solenoid

Type of spool (null position)

01 =  **03** = 

N

Symmetrical flow path control (see hydraulic symbols table)

Flow rating (*) Δp 10 bar
2 = 45 l/min
3 = 60 l/min
5 = 100 l/min

Max. current to solenoid
F = 2.5 A
G = 1.25 A

00 = No variant
P1 = Rotary emergency
V1 = Viton
Q5 = External drainage

1

Serial No.

INPUT SIGNAL CURVES - FLOW RATE

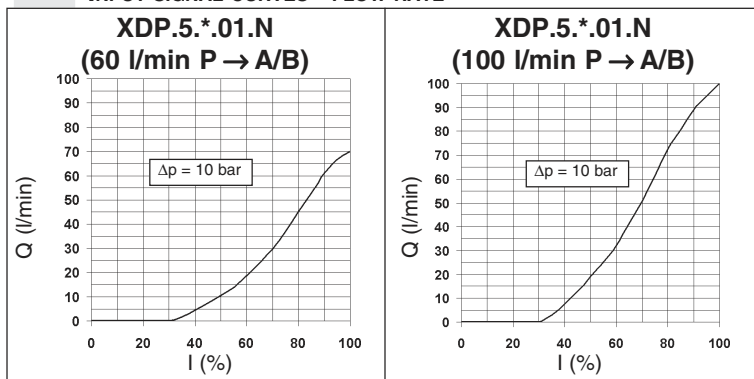

POWER LIMITS TRANSMITTED

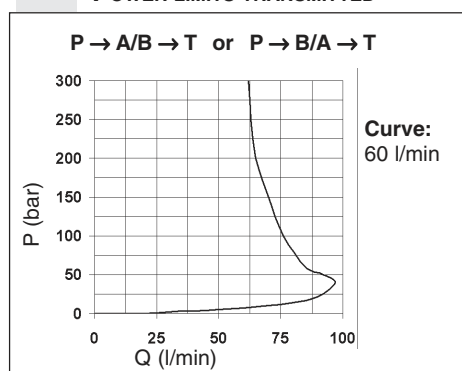

(*) Guaranteed with 24Volt, 2.5Amps supply.

OPERATING SPECIFICATIONS

Max. operating pressure ports P/A/B	320 bar
Max. pressure port T - for dynamic pressure see note (*)	250 bar
Max. pressure port T (with external drainage - Q5 variant)	320 bar
Nominal flow	45 / 60 / 100 l/min
Duty cycle	Continuous 100% ED
Type of protection (depending on the connector used)	IP 65
Flow rate gain	See diagram
Power limits curves transmitted	See diagram
Fluid viscosity	10 ÷ 500 mm ² /s
Fluid temperature	-20°C ÷ 75°C
Ambient temperature	-20°C ÷ 70°C
Max. contamination level	from class 7 at 9 in accordance with NAS 1638 with filter β ₁₀ ≥ 75
Weight XDP.5.A... (single solenoid)	4,97 Kg
Weight XDP.5.C... (double solenoid)	6,55 Kg

Max. current	2.5 A	1.25 A
Solenoid coil resistance 20°C (68°F)	2.85 Ohm	11.4 Ohm
Hysteresis P/A/B/T		
with a pressure compensator AM.5.H.3V...	<5%	<8%
Response to step Δp = 10 bar (P/A)		
0 ÷ 100%	56 ms	118 ms
100% ÷ 0	32 ms	32 ms
Frequency response -3db (Input signal 50% ±25% Vmax)		
	10Hz	7Hz

(*) Pressure dynamic allowed for 2 millions of cycles

Operating specifications are valid for fluids with 46 mm²/s viscosity at 40°C, using the specified ARON electronic control units. Performance data carried out using the specified Aron power amplifier type REM.S.RA... power supplied at 24V.

AMPLIFIER UNIT AND CONTROL

REM.S.RA. and REM.D.RA.****
Electronic card control single and double proportional solenoid valve.

AM.5.H.2V.P1 / AM.5.H.3V.P1 (Δp=10bar)
Hydrostats 2 or 3 way.

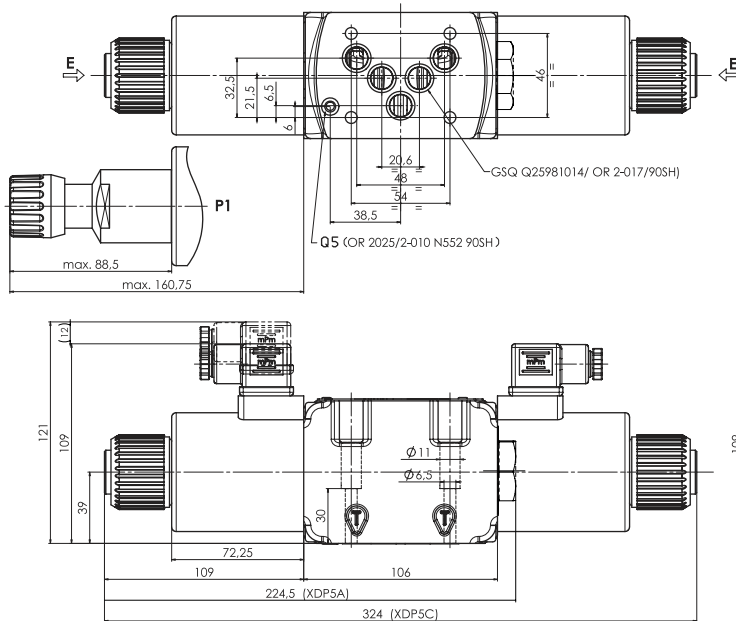

E = Manual override
P1 = Rotary emergency button
Q5 = External draining hole for XDP5 variante Q5 only (**Screws: material specifications 12.9 must be used**)
G5Q = Square section seal

Fixing screws UNI 5931 M6x40
(12.9 material screws are recommended)
Tightening torque 8 ÷ 10 Nm / 0.8 ÷ 1 Kgm

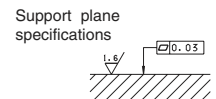

8

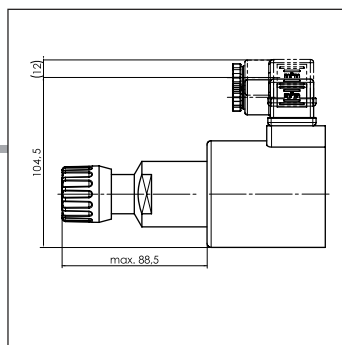

"D19P"
PROPORTIONAL SOLENOIDS

Type of protection (in relation to connector used)	IP 65
Ambient temperature	-54°C ÷ 60°C
Duty cycle	100% ED
Insulation class	H
Weight	1,58 Kg

ETD19P - 01/2002/e