

XQ.3... PROPORTIONAL FLOW CONTROL VALVES PRESSURE COMPENSATED CETOP 3



This is a proportional valve where both the flow rate and pressure control flow functions have been integrated according to the 3 way regulation concept.

The interface UNI ISO 4401 - 03 - 02 - 0 - 94 standard (ex CETOP R 35 H 4.2-4-03) allows for direct mounting on modular block or multiple sub-bases, which makes possible many advantageous and extremely compact application solution as a consequence of their simplicity of installation.

The 3 way type pressure compensator, inserted into the valve, holds the pressure drop across the flow rate proportional regulator constant (approx. 8 bar) independently from the controlled load variations, whereby ensuring proportional between the set flow rate and the electrical command signal.

Additionally, the system maximum safety pressure can be regulated through a manual command. This valve, if mounted on the feed line to the manifold block, can be used to control several circuits which are not operating at the same time.

XQ.3...	
"D15P" PROPORT. SOLENOIDS	CH. VIII PAGE 13
REM.S.RA...	CH. IX PAGE 4
SE.3.AN21.00...	CH. IX PAGE 11
BC.3.08... / BC.3.09...	
BC.06.XQ3...	CH. VII PAGE 13

DIAGRAMS

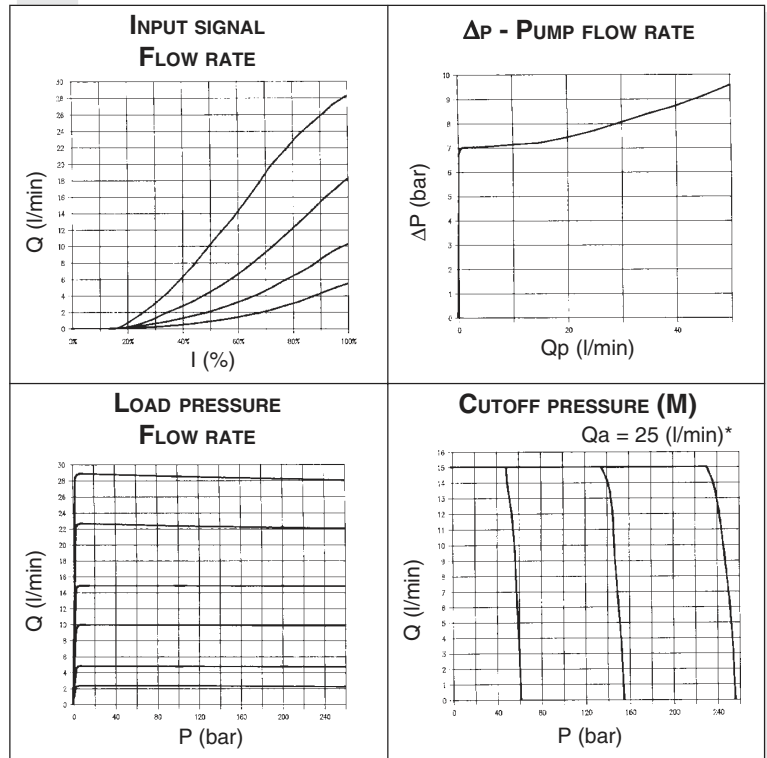

The fluid used is a mineral based oil with a viscosity of 46 mm²/s at 40°C. The tests have been carried out with a fluid of a 40°C.

(*) Tested with 25 l/min supply

ORDERING CODE

XQ	Proportional flow control valve
3	No. of way
C	Pressure compensation
3	CETOP 3/NG6
*	Flow rates F = 5 l/min G = 10 l/min H = 16 l/min I = 28 l/min
*	M = With manual pressure limiter S = Without manual pressure limiter
*	Setting ranges 1 = 8 ÷ 50 bar 2 = 25 ÷ 170 bar 3 = 50 ÷ 315 bar Omit for XQ.3.C.*.S version
*	E = With rotary emergency (type P1) S = Without rotary emergency
*	Voltage E = 9VDC (2,35 A) F = 12VDC (1.76 A) G = 24VDC (0.88 A)
**	00 = No variant V1 = Viton P5 = Rotary emergency 180°
2	Serial No.

TABLE 1 - FLOW / PRESSURE SPECIFICATIONS

Model	Hydraulic symbol	Max flow rate (l/min)	Max flow in P (l/min)	Max limiter pressure (bar)	Max load pressure (bar)	Δp Control (bar)
XQ.3.C.3.*.M		5	40	8÷50	250	8
		10		25÷170		
		16		50÷315		
		28				
XQ.3.C.3.*.S		5	40		250	8
		10				
		16				
		28				

Max. operat. pressure ports A/B / With P port blocked on subplate	315 bar
Max. operating pressure ports T - for dynamic pressure see note (*)	250 bar
Regulated flow rate	See diagram page before
Relative duty cycle	Continuous 100% ED
Type of protection	IEC 144 class IP 65
Flow rate gain	See diagrams
Hysteresis with connection P/A/B/T $\Delta p = 5$ bar (P/A)	$\leq 4\%$ of max. flow rate
Fluid viscosity	$10 \div 500$ mm ² /s
Fluid temperature	$-20^{\circ}\text{C} \div 75^{\circ}\text{C}$
Max. contamination level	class 8 in accordance with NAS 1638 with filter $\beta_{10} \geq 75$
Weight version XQ.3.C.*.M...	2,89 Kg
Weight version XQ.3.C.*.S...	2,39 Kg

Type of voltage	9V	12V	24V
Max. current	2.35A	1.76 A	0.88 A
Solenoid coil resistance at 25°C (77°F)	2.25 Ohm	4.0 Ohm	16.0 Ohm

(*) Pressure dynamic allowed for 2 millions of cycles.

ELECTRONIC CONTROL UNIT

REM.S.RA.*.*

Card type control for single solenoid

SE.3.AN.21.00...

EUROCARD type control for single solenoid

• Operating specifications are valid for fluid with 46 mm²/s viscosity at 40°C, using the specified ARON electronic control units

TYPICAL INSTALLATION

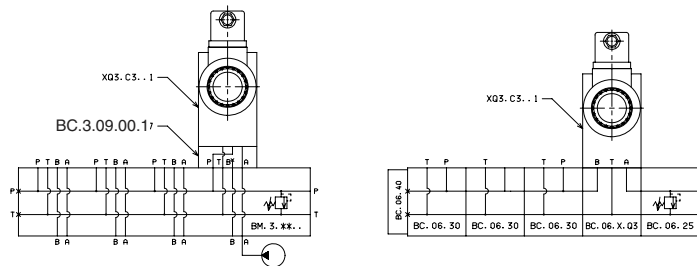

OVERALL DIMENSIONS

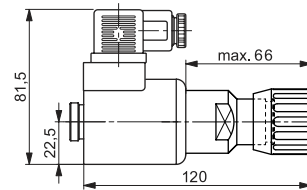
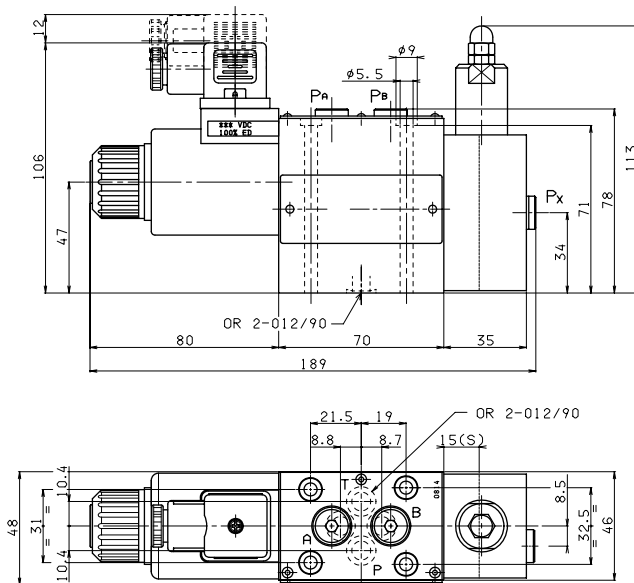

Rotary emergency version XQ.3.C.*.*.E

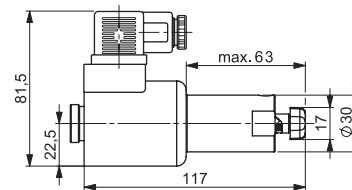

P5 Rotary emergency 180°

Fixing screws UNI 5931 M5x80
(min. 8.8 material screws are recommended)
Tightening torque $4 \div 5$ Nm / $0.4 \div 0.5$ Kgm

Support plane specification

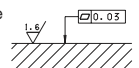

8

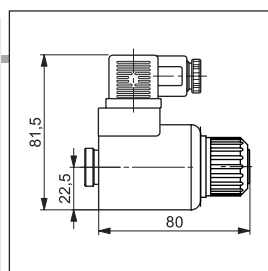

"D15P" PROPORTIONAL SOLENOIDS



Type of protection (in relation to connector used)	IP 66
Duty cycle	100% ED
Insulation class	H
Weight (coil)	0,354 Kg
Weight (solenoid)	0,608 Kg

ETD15P - 01/2002/e