



# XQP.5. OPEN LOOP 2/3 WAY PROPORTIONAL PRESSURE COMPENSATED FLOW REGULATORS CETOP 5



The open loop proportional flow regulator is 2 and 3 way compensated with priority function. It is designed to regulate flow in proportion to an applied electrical current (REM power amplifier). Flow regulation is load independent - B port. Load compensation is achieved by a spool compensator which holds the pressure drop constant across the proportional spool.

Valves are available in the following versions (see hydraulic symbol):

- 2 way pressure compensated
- 3 way pressure compensated with priority function.
- 3 way pressure compensated with priority and venting function.

**XQP.5...**  
 "D19P" PROP. SOLENOIDS CH. VIII PAGE 17  
 REM.S.RA... CH. IX PAGE 4

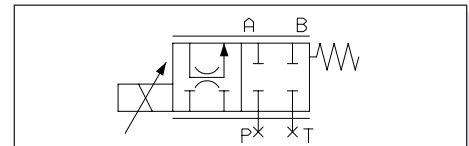

• In order to obtain the 2 way pressure compensated version the cavities P and T have be closed on the subplate.

## SYMBOLS HYDRAULIC

### SIMPLIFIED TYPE

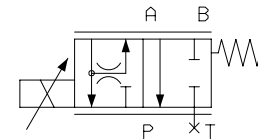
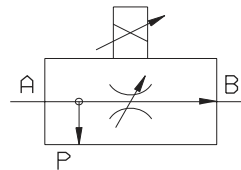

• In order to obtain the 3 way pressure compensated version the cavities T have be closed on the subplate.

## ORDERING CODE

**XQP**

Open loop 2/3 way proportional compensated flow regulator

**5**

CETOP 5/NG10

**C**

2/3 way compensation with priority function

**3**

3 way version (standard)  
 For to obtain 2-way version the P line must be closed on the subplate

**\***

Nominal flow rates  
**F** = 75 l/min  
**G** = 105 l/min

**\***

**S** = without decompression  
**D** = with decompression

**\***

Voltage  
**F** = 12V DC  
**G** = 24V DC

**\*\***

**00** = No variant  
**V1** = Viton

**1**

Serial No.

## DIAGRAMS

**ΔP - FLOW RATE A → B (WITH 5 l/min TO P)**

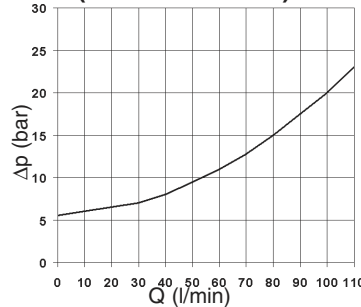

**ΔP - SECONDARY LINE FLOW (A → P FREE)**

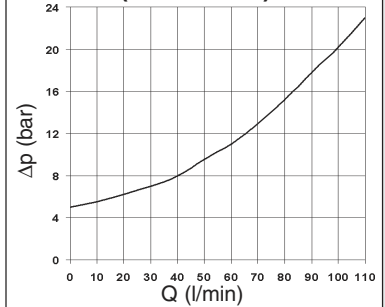

### FLOW RATE

**BACK PRESSURE ON PRIORITY LINE**

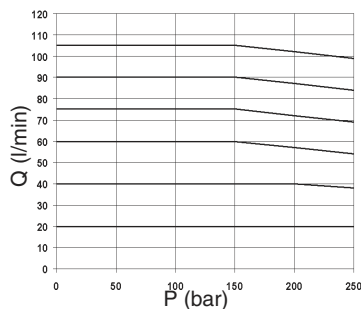

### FLOW RATE

**BACK PRESSURE ON SECONDARY LINE**

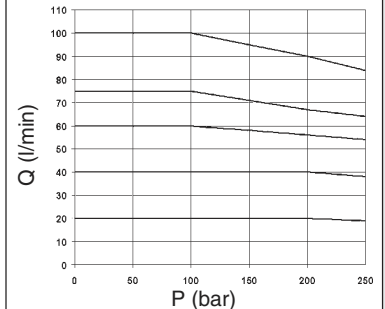

**INPUT SIGNAL FLOW**

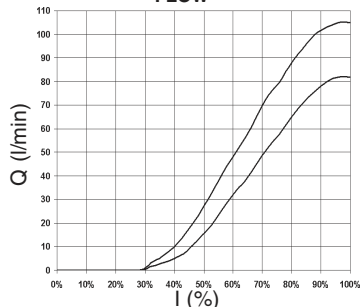

**2 WAY PRESSURE COMPENSATED (A 270 bar - B VARIABLE)**

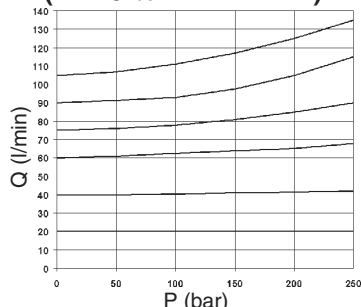

**2 WAY PRESSURE COMPENSATED (A VARIABLE - B 30 bar)**

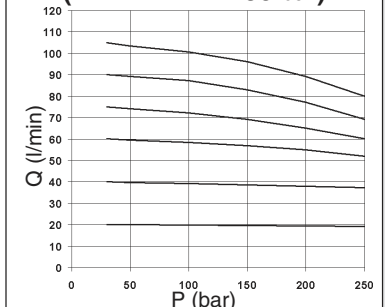

The fluid used is a mineral based oil with a viscosity of 46 mm<sup>2</sup>/s at 40°C.  
 The tests have been carried out at with a fluid of a 40°C.

# XQP.5. OPEN LOOP 2/3 WAY PROPORTIONAL PRESSURE COMPENSATED FLOW REGULATORS CETOP 5



## OPERATING SPECIFICATIONS

Max. operating pressure ports A/B /P (with T ports closed on the subplate)	250 bar
Regulated flow rate	75 / 105 l/min
Decompression drain flow	max 0,7 l/min
Relative duty cycle	Continuous 100% ED
Type of protection (in relation to the connector used)	IP 65
Flow rate gain	See diagram "Input signal flow"
Fluid viscosity	10 ÷ 500 mm <sup>2</sup> /s
Fluid temperature	-20°C ÷ 75°C
Ambient temperature	-20°C ÷ 60°C
Max. contamination level	from class 7 to 9 in accordance with NAS 1638 with filter β <sub>10</sub> ≥ 75
Weight	4,97 Kg

Type of voltage	<b>12V</b>	<b>24V</b>
Max. current	2.5 A	1.25 A
Solenoid coil resistance at 20°C (68°F)	2.85 Ohm	11.4 Ohm
Hysteresis with Δp 7 bar	<5%	<8%
Response to step Δp = 7 bar (P/A)		
0 ÷ 100%	~ 65 ms	-
100% ÷ 0	~ 30 ms	-
Frequency response -3db (Input signal 50% ± 25% Vmax.)	7Hz	-

## AMPLIFIER UNIT AND CONTROL

### REM.S.RA.\*.\*...

Electronic regulator for control single proportional solenoid valve

Operating specifications are valid for fluids with 46 mm<sup>2</sup>/s viscosity at 40°C, using specified ARON electronic control units.

Performance data are carried out using the specified Aron power amplifier type REM.S.RA... power supplied at 24V.

## OVERALL DIMENSIONS

E = Manual override

GSQ = Square section seal

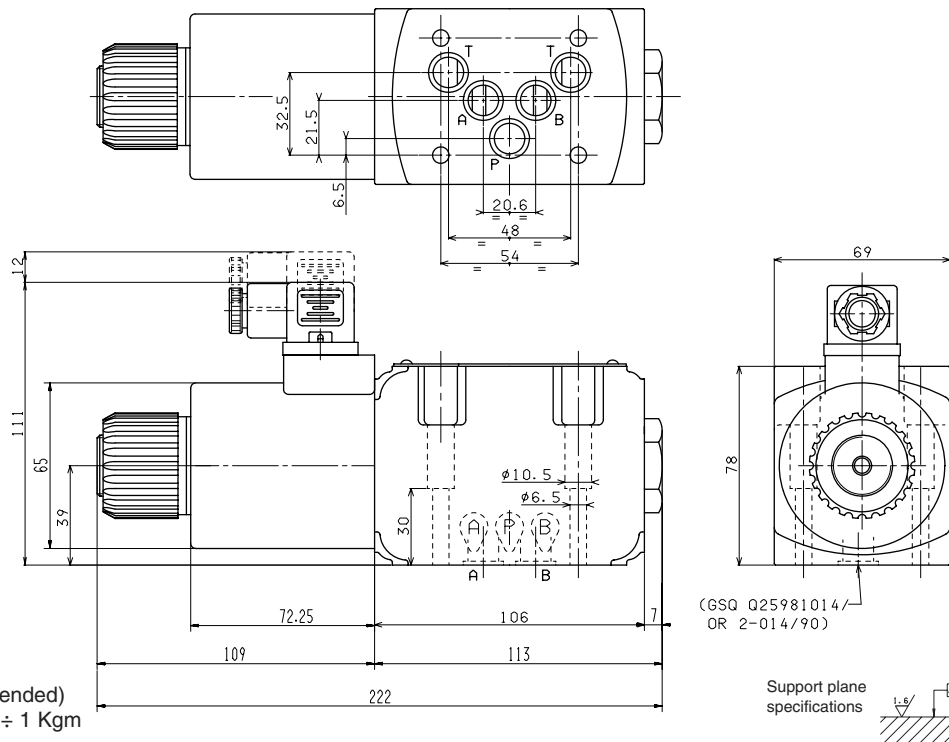

Fixing screws UNI 5931 M6x40  
(12.9 material screws are recommended)  
Tightening torque 8 ÷ 10 Nm / 0.8 ÷ 1 Kgm

8

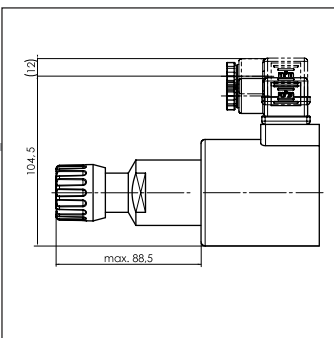

## "D19P" PROPORTIONAL SOLENOIDS



Type of protection (in relation to connector used)	IP 65
Ambient temperature	-54°C ÷ 60°C
Duty cycle	100% ED
Insulation class	H
Weight	1,58 Kg

ETD19P - 01/2002/e