

Steel oil reservoirs for hydraulic hand pumps.

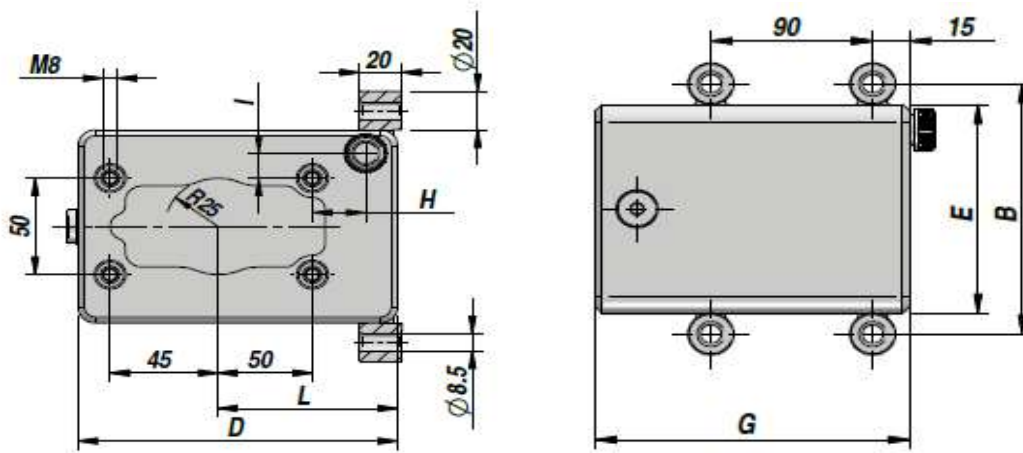
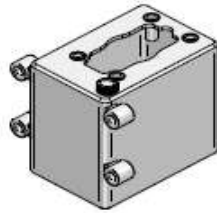

Part nr.	Capacity	Dimensions							Weight
		Liters	B	D	E	G	H	I	
DI.98490	1	120	150	100	120	24	12	90	2
DI.98530	2	120	150	100	180	24	12	90	2,2
DI.98550	3	120	150	100	247	24	12	90	2,5
DI.98630	5	195	175	175	200	42	45	110	4,5
DI.98640	7	195	175	175	269	42	45	110	5,4
DI.98650	10	195	175	175	376	42	45	110	6,8