

# MP80CD

## PRODUCT FEATURE SUMMARY

DATE: 06.12.2025  
MODEL TYPE: MP80CD

Username: Petar Petrov

|  |   |
|--|---|
| <b>CNSORDERNO</b> (Order number)                       | MP80CD  |
| <b>MF</b> (Mounting Flange)                            | omit: Oval mount,two holes                                |
| <b>ONB</b> (Option (needle bearings))                  | omit: none  |
| <b>PT</b> (Port type)                                  | omit: Side ports  |
| <b>DC</b> (Displacement code)                          | 80: 79,2 cm <sup>3</sup> /rev [4.83 in <sup>3</sup> /rev] |
| <b>SE</b> (Shaft Extensions)                           | C: Ø25 straight, Parallel key A8x7x32 DIN6885             |
| <b>SSV</b> (Shaft Seal Version)                        | D: Standard shaft seal                                    |
| <b>DP</b> (Drain Port)                                 | omit: with drain port                                     |
| <b>P</b> (Ports)                                       | omit: BSPP (ISO 228)                                      |
| <b>SFMS</b> (Special Features Measure speed)           | omit: no special features                                 |
| <b>SFGWS</b> (Special Features of gear wheel set)      | omit: no special features                                 |
| <b>SFDR</b> (Special Features - Direction of rotation) | omit: Standard  |
| <b>OP</b> (Option (Paint))                             | omit: no paint  |
| <b>INFO</b> (Info)                                     | PDF catalog   |
| <b>L</b> (Total lengthmm)                              | 139.12  |
| <b>L1</b> (Length of gear wheel setmm)                 | 10.67   |
| <b>DIM</b> (Dimension unit)                            | mm  |

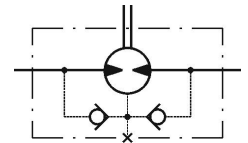

## DATA SHEET

| Type   |                   |
|--|-------------------|
| <b>Displacement, cm<sup>3</sup>/rev [in<sup>3</sup>/rev]</b> | 79,2 [4.83]       |
| <b>Max. Speed, [RPM]</b>                                     | cont. 755         |
|  | Int.* 945         |
| <b>Max. Torque, daNm [lb-in]</b>                             | cont. 15,1 [1340] |
|  | Int.* 19,5 [1725] |
| <b>Max. Output, kW [HP]</b>                                  | cont. 10,2 [13.7] |
|  | Int.* 12,5 [16.8] |
| <b>Max. Pressure Drop, bar [PSI]</b>                         | cont. 140 [2030]  |
|  | Int.* 175 [2540]  |
| <b>Max. Oil Flow, lpm [GPM]</b>                              | cont. 60 [15.9]   |
|  | Int.* 75 [19.8]   |

| Type  |                                       |
|---|---------------------------------------|
| <b>Max. Inlet Pressure, bar [PSI]</b>                 | cont. 175 [2540]                      |
|   | Int.* 200 [2900]                      |
|   | peak** 225 [3260]                     |
| <b>Max. Return Pressure with Drain Line bar [PSI]</b> | cont. 175 [2540]                      |
|   | Int.* 200 [2900]                      |
|   | peak** 225 [3260]                     |
| <b>Pressure with Unloaded Shaft, bar [PSI]</b>        |                                       |
| <b>Min Starting Torque, daNm [lb-in]</b>              | at max. press. drop cont. 13,2 [1170] |
|   | at max. press. drop Int.* 16,8 [1490] |
| <b>Min. Speed***, [RPM]</b>                           | 10                                    |
| <b>Weight, kg [lb]</b>                                | 5,9 [13.2]                            |

\* Intermittent operation: the permissible values may occur for max. 10% of every minute.

\*\* Peak load: the permissible values may occur for max. 1% of every minute.

\*\*\* For speeds lower than given, consult factory or your regional manager.

- Intermittent speed and intermittent pressure drop must not occur simultaneously.
- Recommended filtration is per ISO cleanliness code 20/16. A nominal filtration of 25 micron or better.
- Recommend using a premium quality, anti-wear type mineral based hydraulic oil HLP(DIN51524) or HM ( ISO 6743/4). If using synthetic fluids consult the factory for alternative seal materials.
- Recommended minimum oil viscosity 13 mm<sup>2</sup>/s [70 SUS] at 50°C [122°F].
- Recommended maximum system operating temperature is 82°C [180°F].
- To assure optimum motor life fill with fluid prior to loading and run at moderate load and speed for 10-15 minutes.

# MP80CD

3d generated view

To see model in 3D you should use Acrobat Reader with enable 3D view

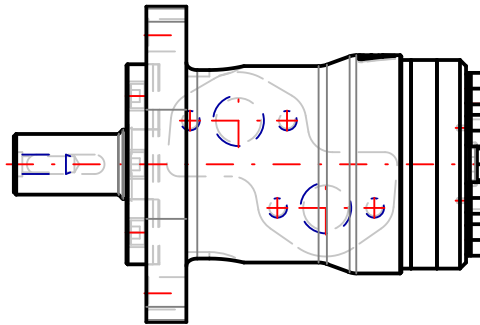
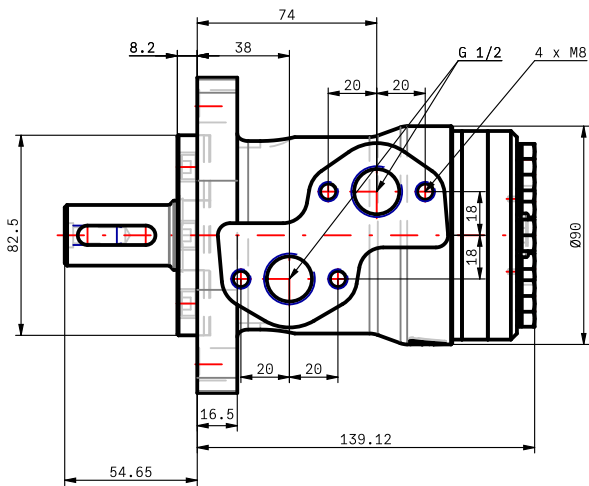
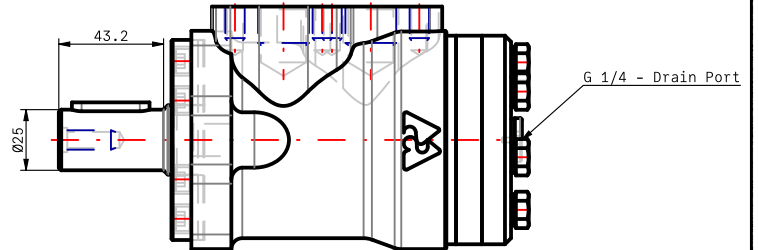
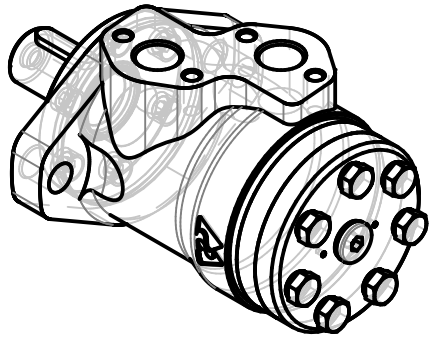

NOTE: Showed dimensions are in nominal, for maximal values see table.  
 NOTE: For additional dimensions and information about flange , shaft , endcover , etc. see next page.

|        |        |
|--------|--------|
| L max  | LS max |
| 139.12 |        |

Confidential property of M+S Hydraulic, Bulgaria.  
 Please note that this drawing is automatically generated based on the selection. In case of possible changes or revisions in the drawing specifications, the selection process should be repeat M+S is not responsible for any possible errors on the drawings.



MP80CD

Design: M+S      Check:

|                 |       |      |            |
|-----------------|-------|------|------------|
| Scale           | Sheet | Rev. | Weight     |
| Date 06.12.2025 |       |      | 5,9 [13.2] |

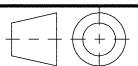

**Standard Rotation**  
Viewed from Shaft End

Port A Pressurized - CW  
Port B Pressurized - CCW

omit: Oval mount, two holes

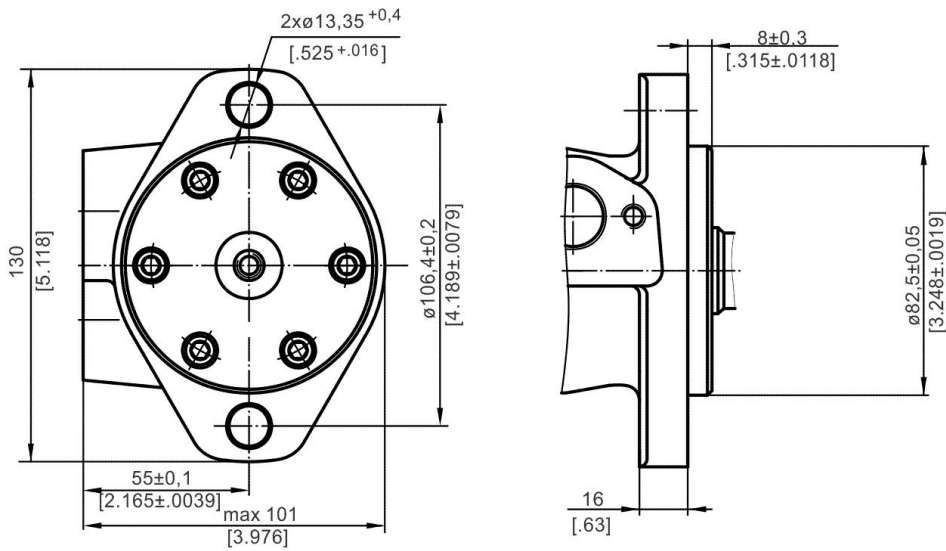

omit: Side ports

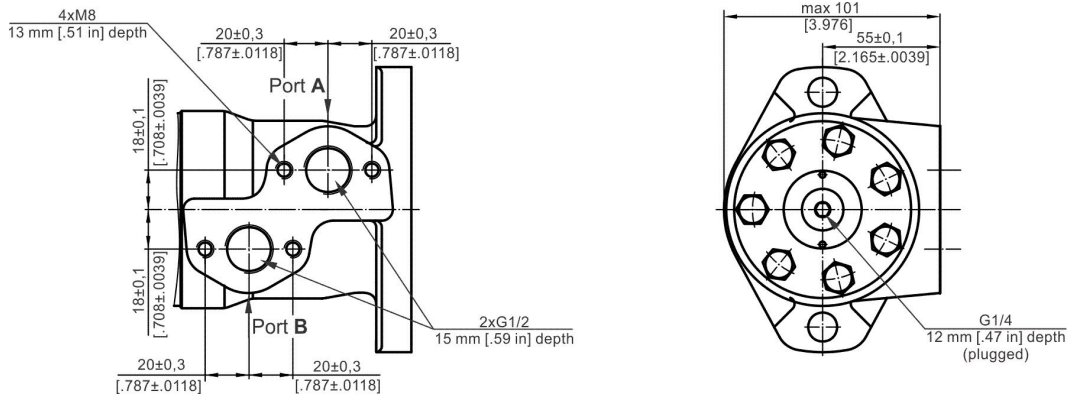

C: o25 straight, Parallel key A8x7x32 DIN6885

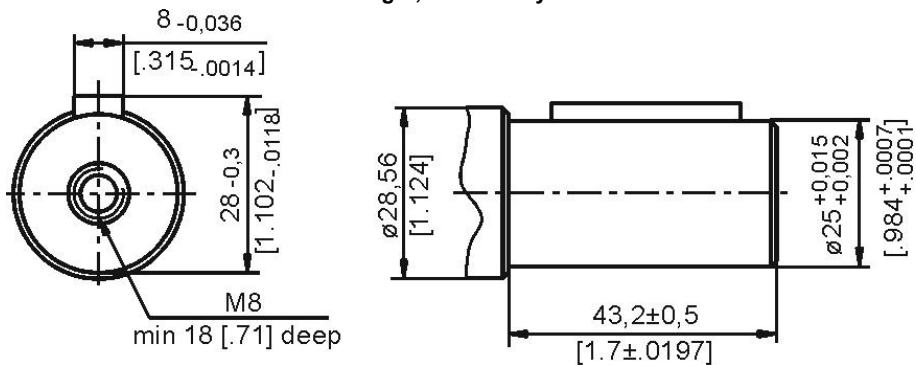

Confidential property of M+S Hydraulic, Bulgaria.  
Please note that this drawing is automatically generated based on the selection. In case of possible changes or revisions in the drawing specifications, the selection process should be repeat. M+S is not responsible for any possible errors on the drawings.



**MP80CD**

Design: M+S      Check:

|                 |       |      |            |
|-----------------|-------|------|------------|
| Scale           | Sheet | Rev. | Weight     |
| Date 06.12.2025 |       |      | 5.9 [13.2] |

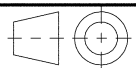

# MP80CD

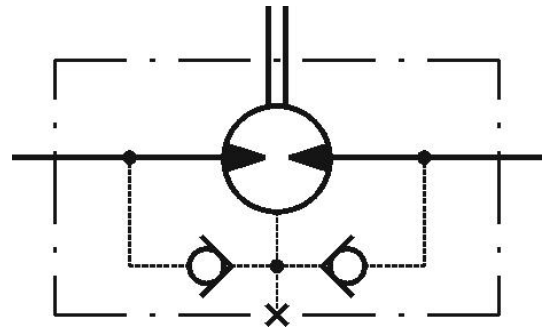

The shaft seal pressure equals the pressure in the drain line

## FUNCTION DIAGRAMS

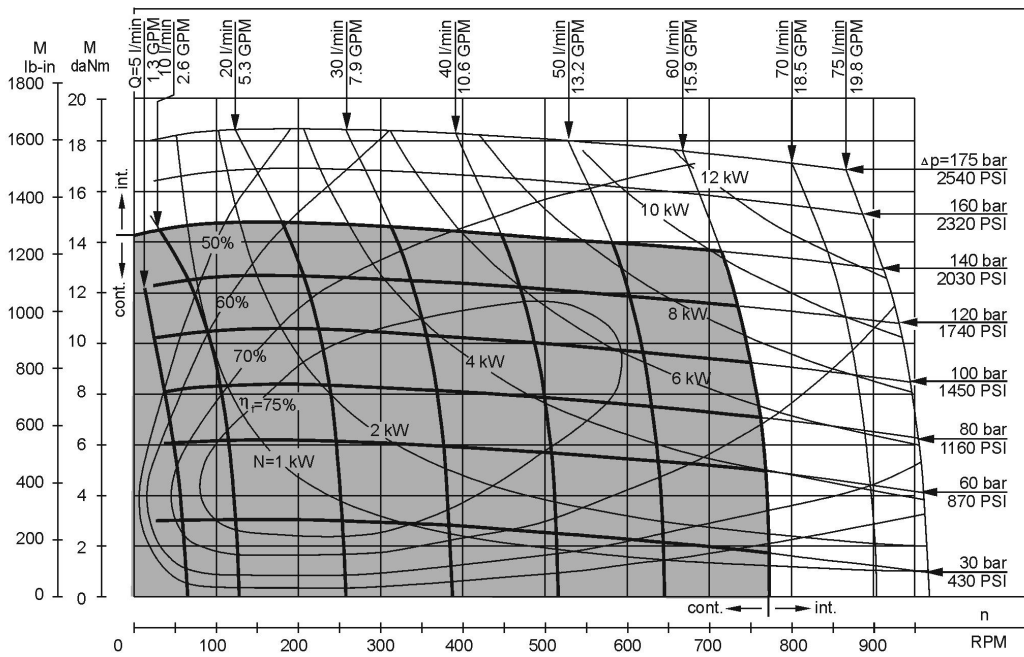

The function diagrams data is for average performance of randomly selected motors at back pressure 5±10 bar [72.5±145 PSI] and oil with viscosity of 32 mm<sup>2</sup>/s [150 SUS] at 50°C [122°F].

# MP80CD

## DATA SHEET

### Pressure Losses



### Oil flow in drain line

| Pressure drop bar [PSI] | Viscosity mm <sup>2</sup> /s [SUS] | Oil flow in drain line lpm [GPM] |
|-------------------------|------------------------------------|----------------------------------|
| 100 [1450]              | 20 [98]                            | 2,5 [.660]                       |
|                         | 35 [164]                           | 1,8 [.476]                       |
| 140 [2030]              | 20 [98]                            | 3,5 [.925]                       |
|                         | 35 [164]                           | 2,8 [.740]                       |

### MAX: PERMISSIBLE SHAFT SEAL PRESSURE

Max. return pressure without drain line or max. pressure in the drain line

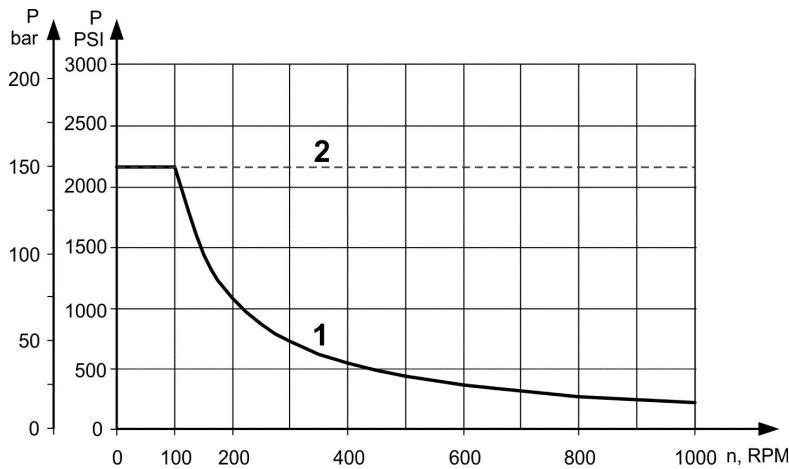

Curve "1" shows continuous operations.  
Curve "2" shows intermittent operations.

### PERMISSIBLE SHAFT LOADS

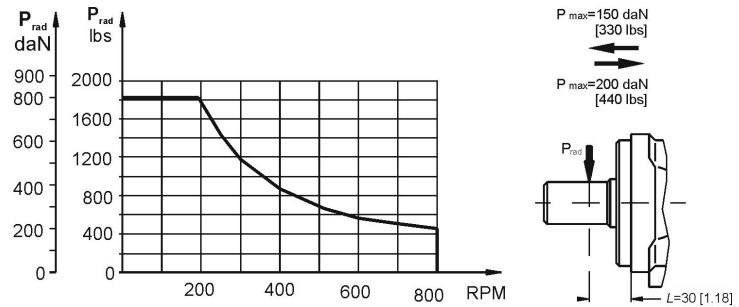

Radial Shaft Load Prad for C,CO Shaft Extensions by L=30mm[1.81in]