

MP160CD

PRODUCT FEATURE SUMMARY

DATE: 08.12.2025

Username: Petar Petrov

MODEL TYPE: MP160CD

CNSORDERNO (Order number)	MP160CD
MF (Mounting Flange)	omit: Oval mount,two holes
ONB (Option (needle bearings))	omit: none
PT (Port type)	omit: Side ports
DC (Displacement code)	160: 158,4 cm ³ /rev [9.66 in ³ /rev]
SE (Shaft Extensions)	C: Ø25 straight, Parallel key A8x7x32 DIN6885
SSV (Shaft Seal Version)	D: Standard shaft seal
DP (Drain Port)	omit: with drain port
P (Ports)	omit: BSPP (ISO 228)
SFMS (Special Features Measure speed)	omit: no special features
SFGWS (Special Features of gear wheel set)	omit: no special features
SFDR (Special Features - Direction of rotation)	omit: Standard
OP (Option (Paint))	omit: no paint
INFO (Info)	PDF catalog
L (Total lengthmm)	149.78
L1 (Length of gear wheel setmm)	21.33
DIM (Dimension unit)	mm

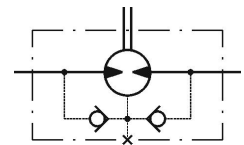

DATA SHEET

Type		
Displacement, cm³/rev [in³/rev]		158,4 [9.66]
Max. Speed, [RPM]	cont.	378
	Int.*	472
Max. Torque, daNm [lb-in]	cont.	31,3 [2770]
	Int.*	37,8 [3345]
Max. Output, kW [HP]	cont.	10,1 [13.5]
	Int.*	12,1 [16.2]
Max. Pressure Drop, bar [PSI]	cont.	140 [2030]
	Int.*	175 [2540]
Max. Oil Flow, lpm [GPM]	cont.	60 [15.9]
	Int.*	75 [19.8]

Type		
Max. Inlet Pressure, bar [PSI]	cont.	175 [2540]
	Int.*	200 [2900]
	peak**	225 [3260]
Max. Return Pressure with Drain Line bar [PSI]	cont.	175 [2540]
	Int.*	200 [2900]
	peak**	225 [3260]
Pressure with Unloaded Shaft, bar [PSI]		8 [116]
Min Starting Torque, daNm [lb-in]	at max. press. drop cont.	28,2 [2500]
	at max. press. drop Int.*	35,5 [3140]
Min. Speed***, [RPM]		10
Weight, kg [lb]		6,4 [14.1]

* Intermittent operation: the permissible values may occur for max. 10% of every minute.

** Peak load: the permissible values may occur for max. 1% of every minute.

*** For speeds lower than given, consult factory or your regional manager.

- Intermittent speed and intermittent pressure drop must not occur simultaneously.
- Recommended filtration is per ISO cleanliness code 20/16. A nominal filtration of 25 micron or better.
- Recommend using a premium quality, anti-wear type mineral based hydraulic oil HLP(DIN51524) or HM (ISO 6743/4). If using synthetic fluids consult the factory for alternative seal materials.
- Recommended minimum oil viscosity 13 mm²/s [70 SUS] at 50°C [122°F].
- Recommended maximum system operating temperature is 82°C [180°F].
- To assure optimum motor life fill with fluid prior to loading and run at moderate load and speed for 10-15 minutes.

MP160CD

3d generated view

To see model in 3D you should use Acrobat Reader with enable 3D view

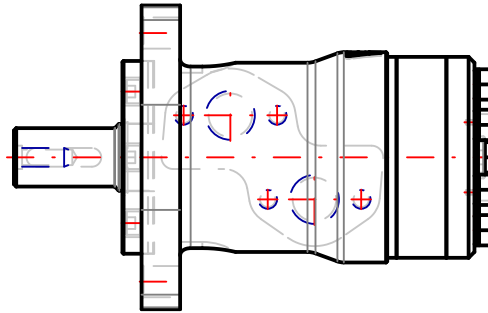
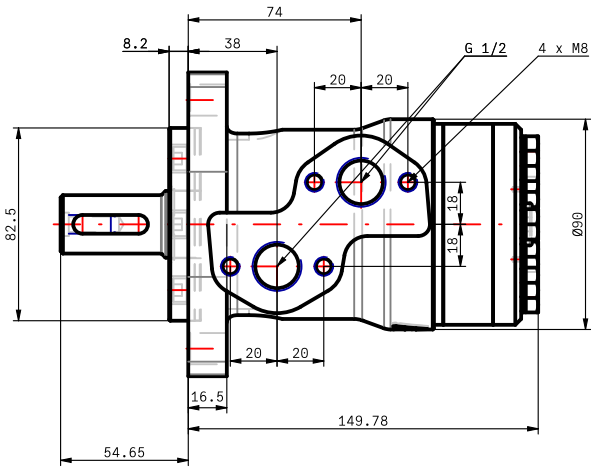
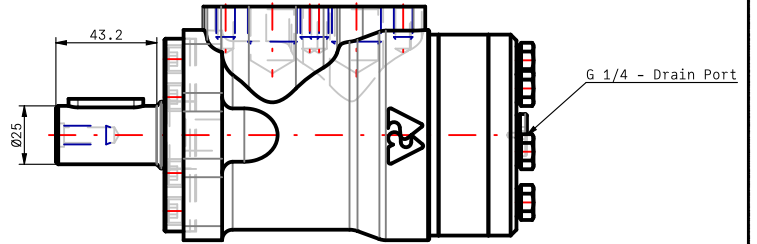
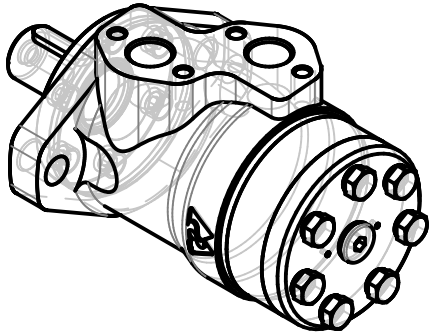

NOTE: Shown dimensions are in nominal, for maximal values see table.
 NOTE: For additional dimensions and information about flange , shaft , endcover , etc. see next page.

L max	LS max
149.78	

Confidential property of M+S Hydraulic, Bulgaria.
 Please note that this drawing is automatically generated based on the selection. In case of possible changes or revisions in the drawing specifications, the selection process should be repeat M+S is not responsible for any possible errors on the drawings.



MP160CD

Design: M+S

Check:

Scale	Sheet	Rev.	Weight
Date 08.12.2025			6.4 [14.1]

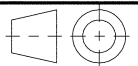

Standard Rotation
Viewed from Shaft End

Port A Pressurized - CW
Port B Pressurized - CCW

omit: Oval mount, two holes

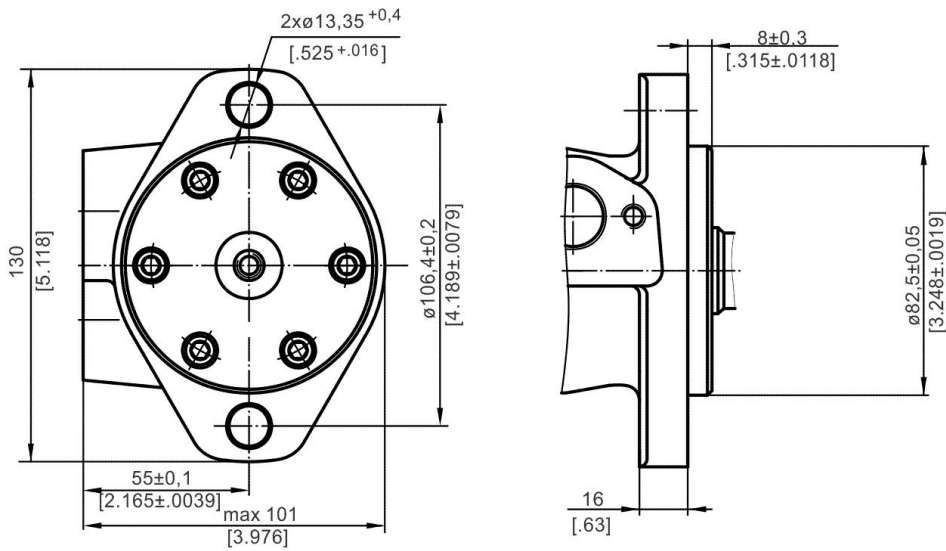

omit: Side ports

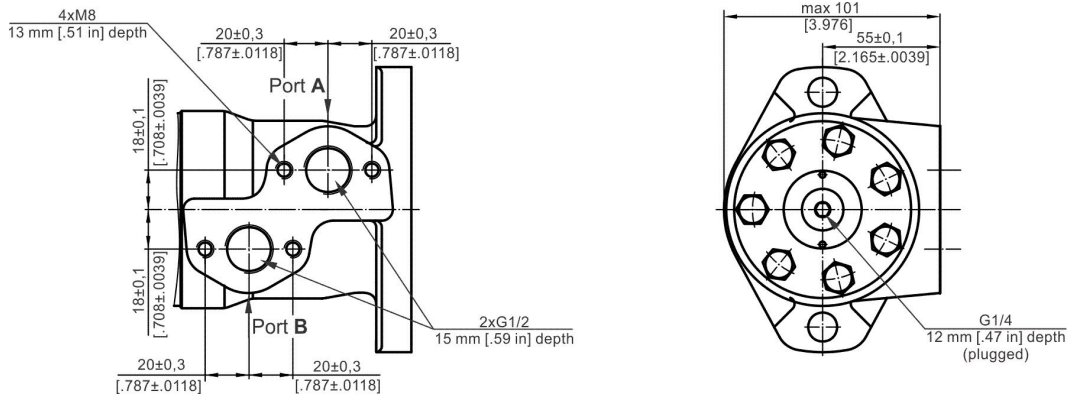

C: o25 straight, Parallel key A8x7x32 DIN6885

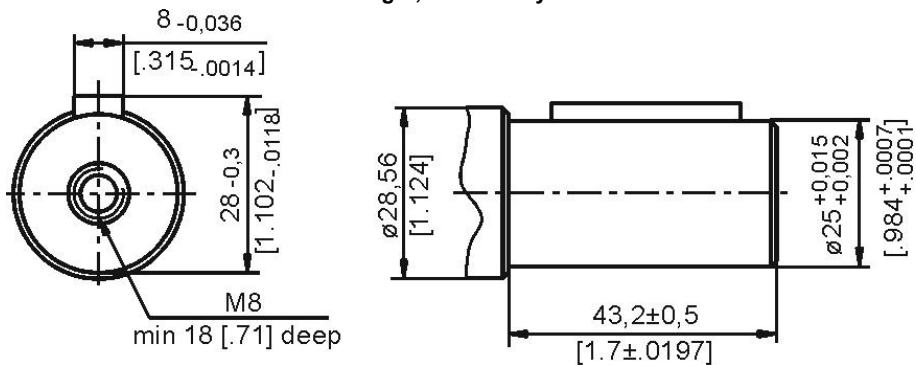

Confidential property of M+S Hydraulic, Bulgaria.
Please note that this drawing is automatically generated based on the selection. In case of possible changes or revisions in the drawing specifications, the selection process should be repeat. M+S is not responsible for any possible errors on the drawings.



MP160CD

Scale	Sheet	Rev.	Weight
Date 08.12.2025			6.4 [14.1]

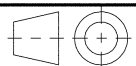

MP160CD

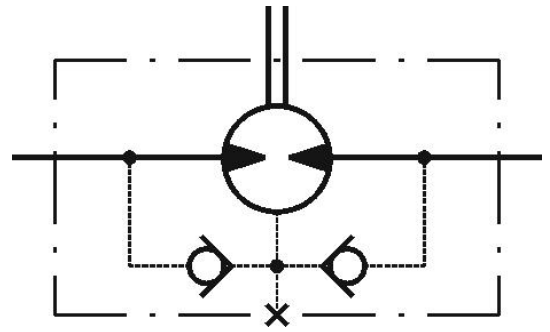

The shaft seal pressure equals the pressure in the drain line

FUNCTION DIAGRAMS

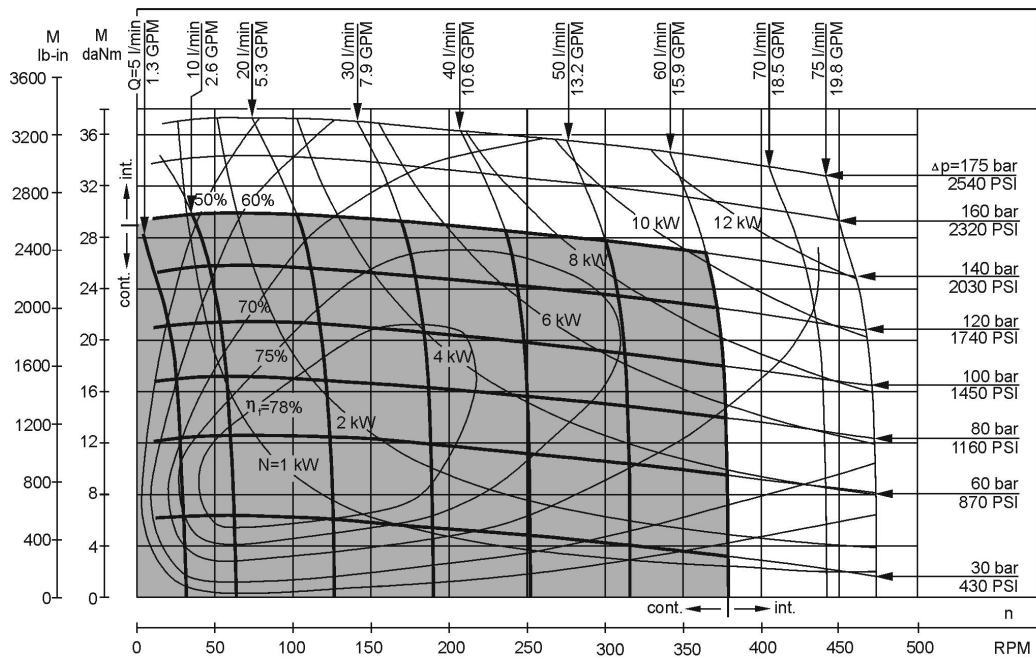

The function diagrams data is for average performance of randomly selected motors at back pressure 5±10 bar [72.5±145 PSI] and oil with viscosity of 32 mm²/s [150 SUS] at 50°C [122°F].

MP160CD

DATA SHEET

Pressure Losses

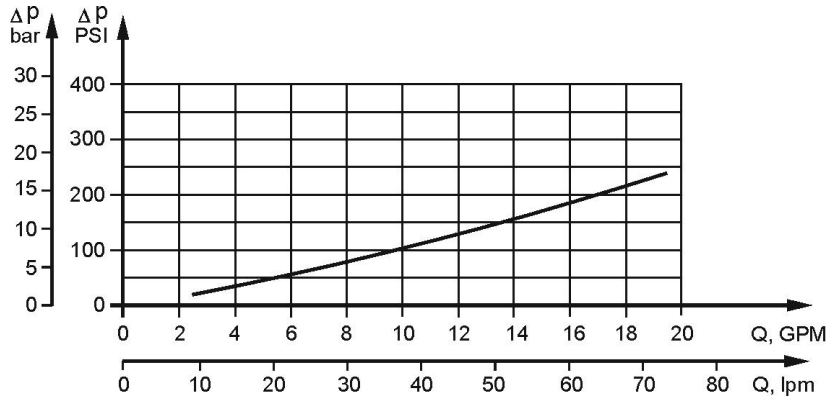

Oil flow in drain line

Pressure drop bar [PSI]	Viscosity mm ² /s [SUS]	Oil flow in drain line lpm [GPM]
100 [1450]	20 [98]	2,5 [.660]
	35 [164]	1,8 [.476]
140 [2030]	20 [98]	3,5 [.925]
	35 [164]	2,8 [.740]

MAX: PERMISSIBLE SHAFT SEAL PRESSURE

Max. return pressure without drain line or max. pressure in the drain line

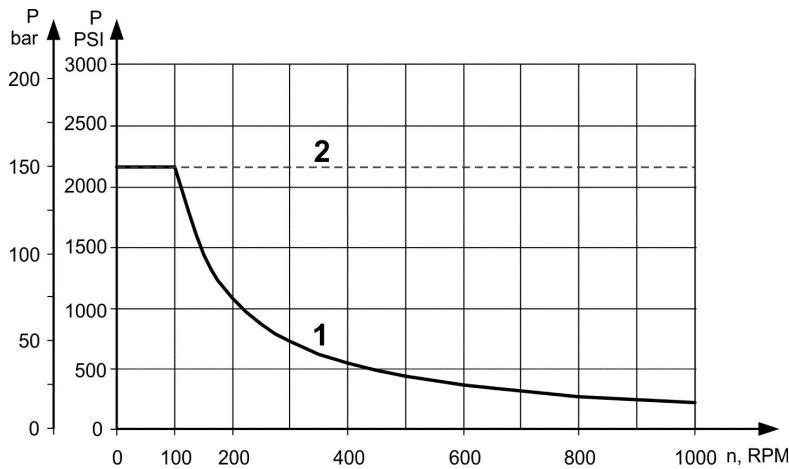

Curve "1" shows continuous operations.
Curve "2" shows intermittent operations.

PERMISSIBLE SHAFT LOADS

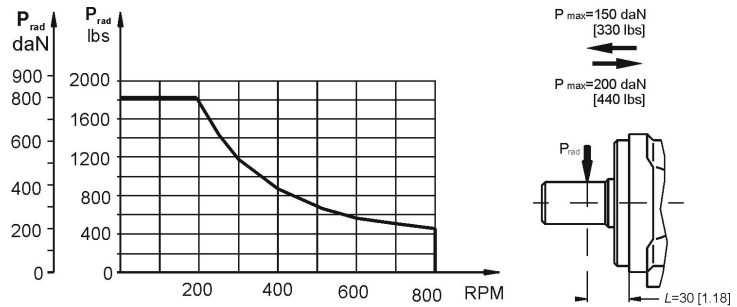

Radial Shaft Load Prad for C,CO Shaft Extensions by L=30mm[1.81in]