

MS100C/4

PRODUCT FEATURE SUMMARY

DATE: 10.12.2025

Username: Petar Petrov

MODEL TYPE: MS100C/4

CNSORDERNO (Order number).	MS100C/4
MF (Mounting Flange).	omit: SAE A-4 mount, four holes
PT (Port type).	omit: Side ports
DC (Displacement code).	100: 100,0 cm ³ /rev [6.10 in ³ /rev]
SE (Shaft Extensions).	C: ø32 straight, Parallel key A10x8x45 DIN6885
SSV (Shaft Seal Version).	omit: Low pressure seal
P (Ports).	omit: BSPP (ISO 228)
AD (Actuating Direction).	omit: only for drum brake
SFMS (Special Features measure speed).	omit: no special features
SFGWS (Special Features of gear wheel set).	omit: no special features
SFDR (Special Features – Direction of rotation).	omit: Standard
OP (Option (Paint)).	omit: no paint
DESIGNS (Design Series).	4
INFO (Info).	PDF catalog
L1 (mm).	17.4
L2 (mm).	127.3
L (max. Lmm).	168.7

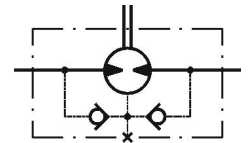

DATA SHEET

Type	MS100
Displacement, cm³/rev [in³/rev]	100 [6.1]
Max. Speed, [RPM]	cont. 750
	Int.* 900
Max. Torque, daNm [lb-in]	cont. 30,5 [2700]
	Int.* 39 [3450]
Max. Output, kW [HP]	cont. 18 [24.1]
	Int.* 22,8 [30.2]
Max. Pressure Drop, bar [PSI]	cont. 210 [3050]
	Int.* 275 [3990]
Max. Oil Flow, lpm[GPM]	cont. 75 [20]
	Int.* 90 [24]

Type	MS100
Max. Inlet Pressure, bar [PSI]	cont. 230 [3340]
	Int.* 295 [4280]
	peak** 300 [4350]
Max. Return Pressure with Drain Line bar [PSI]	cont. 140 [2030]
	Int.* 175 [2540]
	peak** 210 [3050]
Pressure with Unloaded Shaft, bar [PSI]	
10 [145]	
Min Starting Torque, daNm [lb-in]	at max. press. drop cont. 23 [2040]
	at max. press. drop Int.* 30 [2660]
Min. Speed***, [RPM]	10
Weight, kg [lb]	10,1 [22.2]

* Intermittent operation: the permissible values may occur for max. 10% of every minute.

** Peak load: the permissible values may occur for max. 1% of every minute.

*** For speeds lower than given, consult factory or your regional manager.

- Intermittent speed and intermittent pressure drop must not occur simultaneously.
- Recommended filtration is per ISO cleanliness code 20/16. A nominal filtration of 25 micron or better.
- Recommend using a premium quality, anti-wear type mineral based hydraulic oil HLP(DIN51524) or HM (ISO 6743/4). If using synthetic fluids consult the factory for alternative seal materials.
- Recommended minimum oil viscosity 13 mm²/s [70 SUS] at 50°C [122°F].
- Recommended maximum system operating temperature is 82°C [180°F].
- To assure optimum motor life fill with fluid prior to loading and run at moderate load and speed for 10-15 minutes.

MS100C/4

3d generated view

To see model in 3D you should use Acrobat Reader with enable 3D view

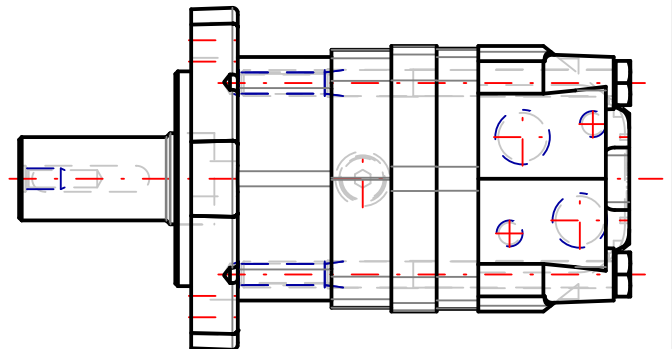
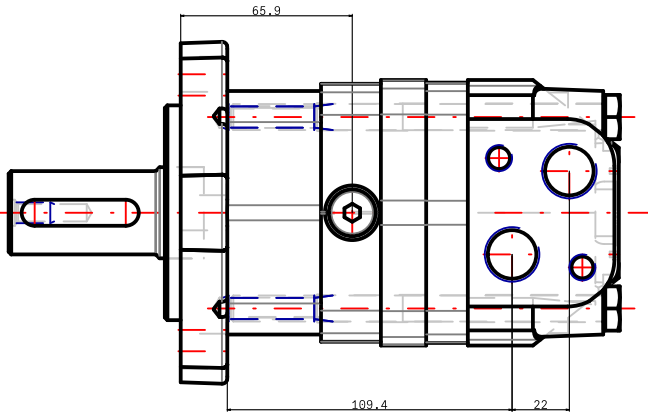
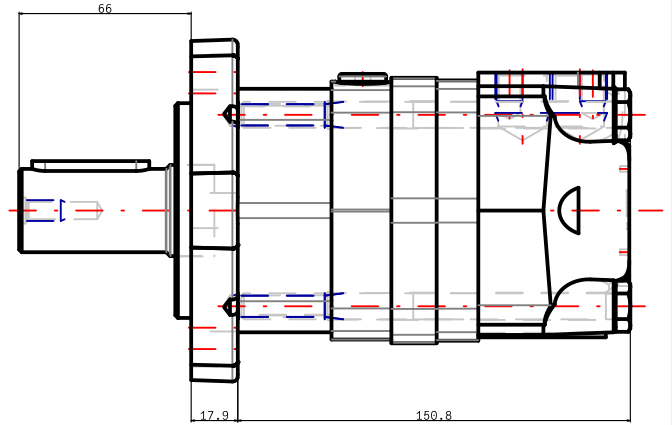
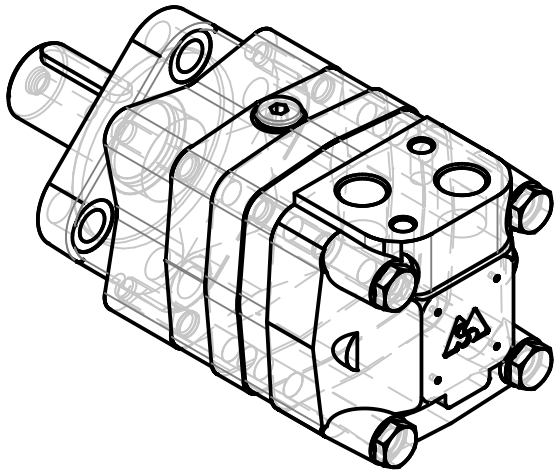

NOTE: Shown dimensions are in nominal, for maximal values see table.

NOTE: For additional dimensions and information about flange , shaft , endcover , etc. see next page.

L max	LS max
168.7	127.3

Confidential property of M+S Hydraulic, Bulgaria.
Please note that this drawing is automatically generated based on the selection. In case of possible changes or revisions in the drawing specifications, the selection process should be repeat. M+S is not responsible for any possible errors on the drawings.



MS100C/4

Design: M+S Check:

Scale	Sheet	Rev.	Weight
Date 10.12.2025		4	10,1 [22.2]

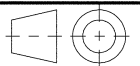

Standard Rotation
Viewed from Shaft End

Port A Pressurized - CW
Port B Pressurized - CCW

omit: SAE A-4 mount, four holes

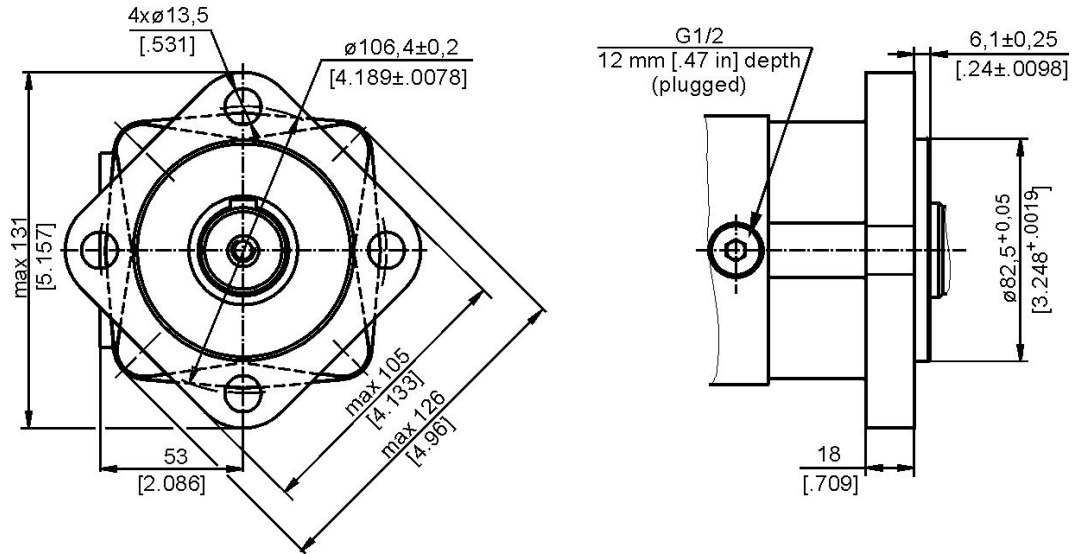

omit: Side ports

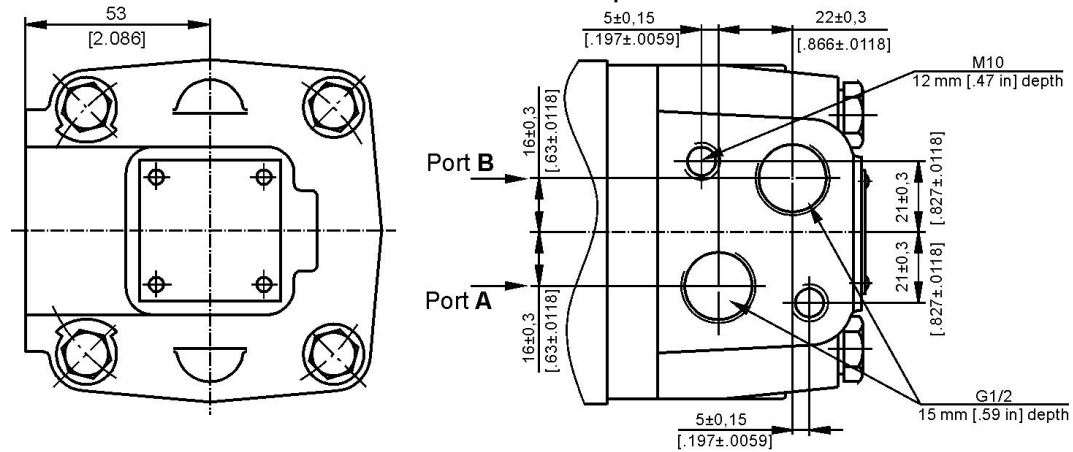

C: Ø32 straight, Parallel key A10x8x45 DIN6885

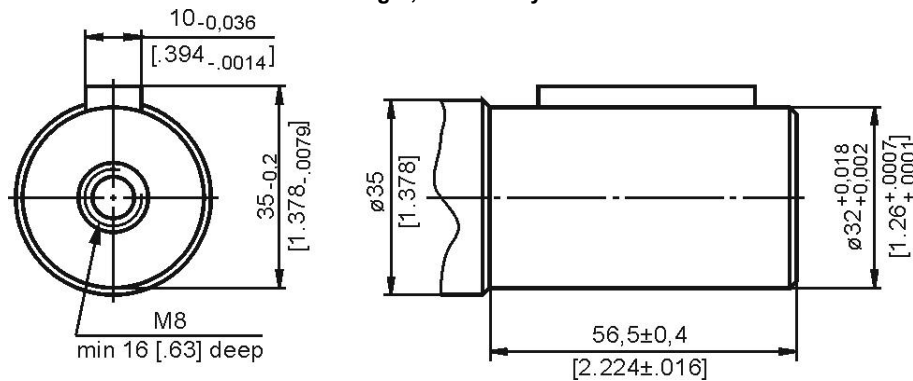

Confidential property of M+S Hydraulic, Bulgaria.
Please note that this drawing is automatically
generated based on the selection. In case of
possible changes or revisions in the drawing
specifications, the selection process should be
repeat. M+S is not responsible for any possible
errors on the drawings.



MS100C/4

Scale	Sheet	Rev.	Weight
Date 10.12.2025		4	10,1 [22.2]

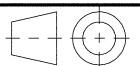

MS100C/4

FUNCTION DIAGRAMS

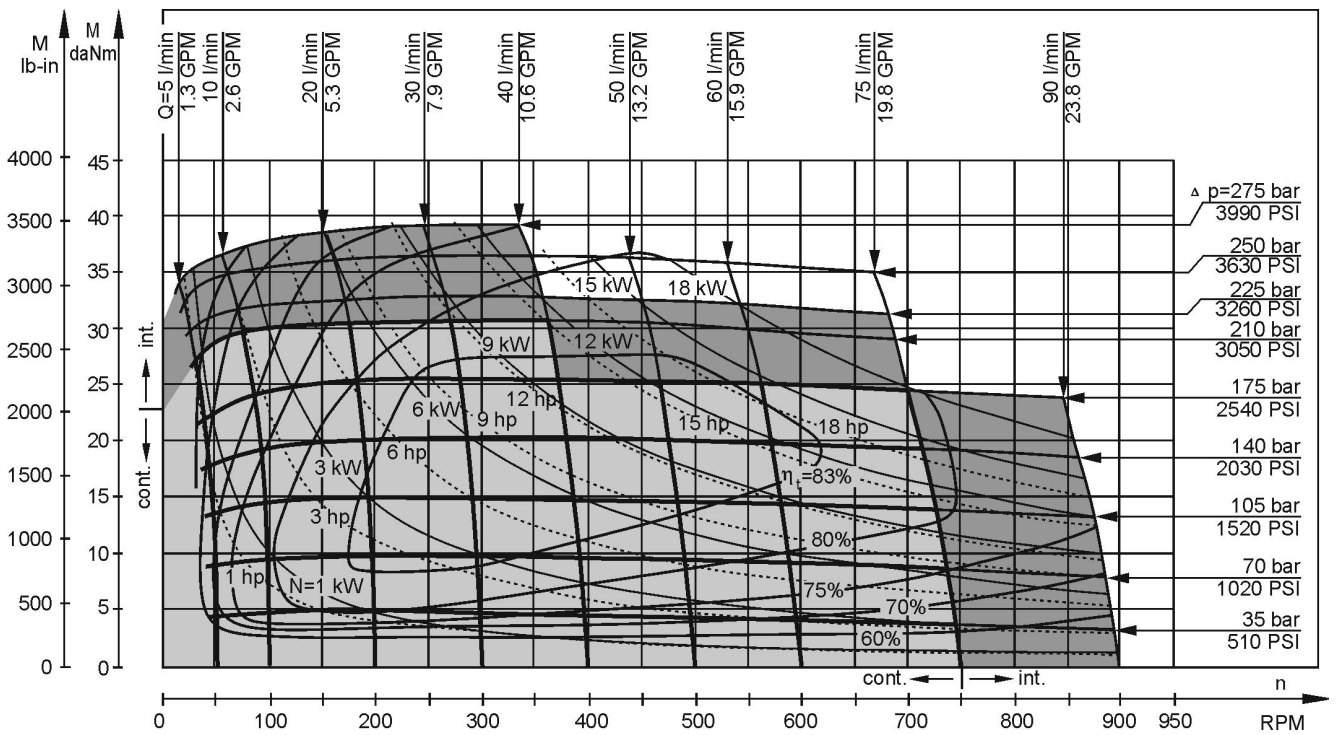

The function diagrams data is for average performance of randomly selected motors at back pressure 5±10 bar [72.5±145 PSI] and oil with viscosity of 32 mm²/s [150 SUS] at 50°C [122°F].

MS100C/4

DATA SHEET

Pressure Losses

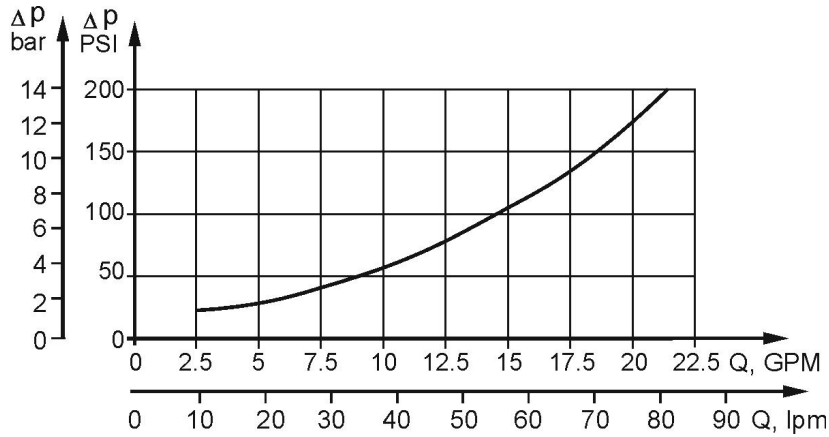

Oil flow in drain line

Pressure drop bar [PSI]	Viscosity mm ² /s [SUS]	Oil flow in drain line lpm [GPM]
140 [2030]	20 [98]	1,5 [.396]
	35 [164]	1 [.264]
210 [3045]	20 [98]	3 [.793]
	35 [164]	2 [.528]

MAX: PERMISSIBLE SHAFT SEAL PRESSURE

Max. return pressure without drain line or max. pressure in the drain line

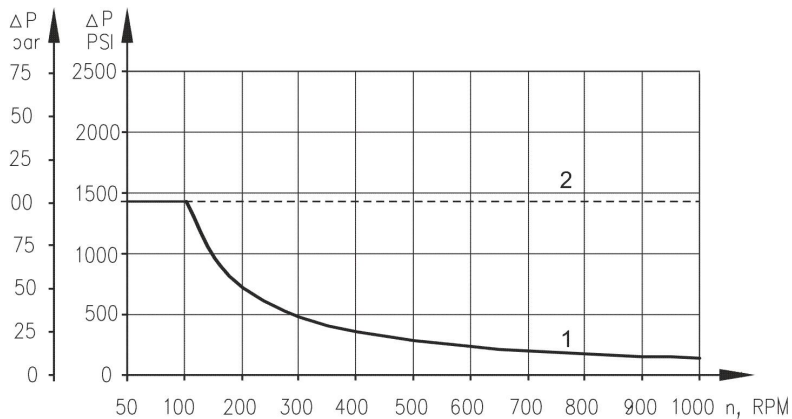

Curve "1" shows continuous operations.
Curve "2" shows intermittent operations.

PERMISSIBLE SHAFT LOADS

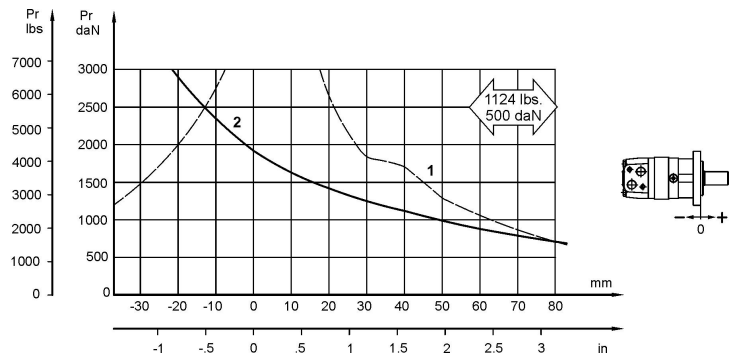

Curve "1" shows critical radial shaft load. The output shaft runs in tapered bearings that permit high axial and radial forces. The permissible radial load on the shaft is shown (curve 2) for an axial load of 0 N as function of the distance from the mounting flange to the point of load application. The curve 2 apply to a B10 bearing life of 2000 hours at 100 RPM.