

MT200K

PRODUCT FEATURE SUMMARY

DATE: 10.12.2025
MODEL TYPE: MT200K

Username: Petar Petrov

CNSORDERNO (Order number)	MT200K
MF (Mounting Flange)	omit: Square mount, four holes
PT (Port type)	omit: Side ports
DC (Displacement code)	200: 201,4 cm ³ /rev [12.29 in ³ /rev]
SE (Shaft Extensions)	K: \varnothing 45 tapered 1:10, Parallel key B12x8x28 DIN6885
SSV (Shaft Seal Version)	omit: Low pressure seal
P (Ports)	omit: BSPP (ISO 228)
SFMS (Special Features Measure speed)	omit: no special features
SFRM (Special Features Reinforced motor)	omit: no special features
SFGWS (Special Features of gear wheel set)	omit: no special features
SFDR (Special Features - Direction of rotation)	omit: Standard
OP (Option (Paint))	omit: no paint
INFO (INFO)	PDF catalog
L (mm)	197.1
L1 (mm)	21.2
L2 (mm)	147.0

DATA SHEET

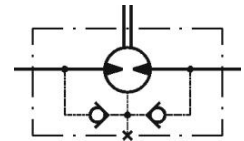

Type	
Displacement, cm³/rev [in³/rev]	201,4[12.29]
Max. Speed, [RPM]	cont. 620
	Int.* 752
Max. Torque, daNm [lb-in]	cont. 59[5220]
	Int.* 71[6285]
Max. Output, kW [HP]	cont. 33,5[45]
	Int.* 40[54]
Max. Pressure Drop, bar [PSI]	cont. 200[2900]
	Int.* 240[3480]
Max. Oil Flow, lpm [GPM]	cont. 125[33]
	Int.* 150[39.6]

Type	
Max. Inlet Pressure, bar [PSI]	cont. 210[3050]
	Int.* 250[3600]
	peak** 300[4350]
Max. Return Pressure with Drain Line bar [PSI]	cont. 140[2030]
	Int.* 175[2540]
	peak** 210[3050]
Pressure with Unloaded Shaft, bar [PSI]	
Min Starting Torque, daNm [lb-in]	at max. press. drop cont. 43[3800]
	at max. press. drop Int.* 52[4600]
Min. Speed***, [RPM]	9
Weight, kg [lb]	21,5 [47.4]

* Intermittent operation: the permissible values may occur for max. 10% of every minute.

** Peak load: the permissible values may occur for max. 1% of every minute.

*** For speeds lower than given, consult factory or your regional manager.

- Intermittent speed and intermittent pressure drop must not occur simultaneously.
- Recommended filtration is per ISO cleanliness code 20/16. A nominal filtration of 25 micron or better.
- Recommend using a premium quality, anti-wear type mineral based hydraulic oil HLP(DIN51524) or HM (ISO 6743/4).
If using synthetic fluids consult the factory for alternative seal materials.
- Recommended minimum oil viscosity 13 mm²/s [70 SUS] at 50°C [122°F].
- Recommended maximum system operating temperature is 82°C [180°F].
- To assure optimum motor life fill with fluid prior to loading and run at moderate load and speed for 10-15 minutes.

MT200K

3d generated view

To see model in 3D you should use Acrobat Reader with enable 3D view

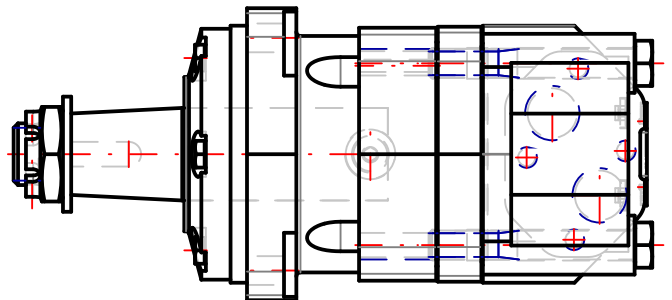
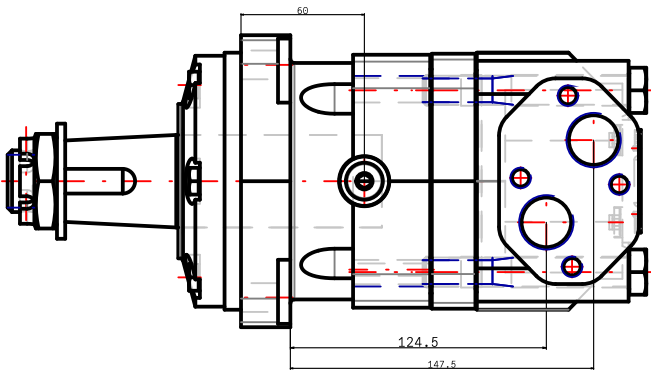
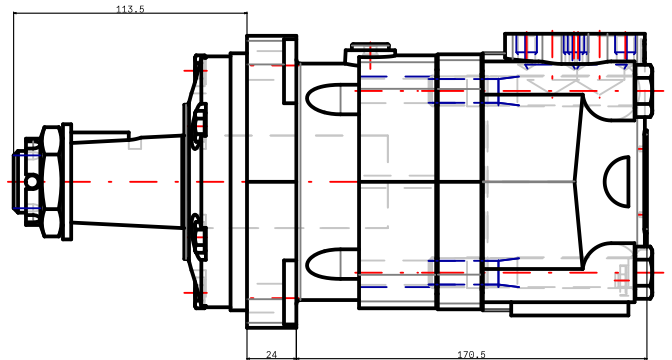
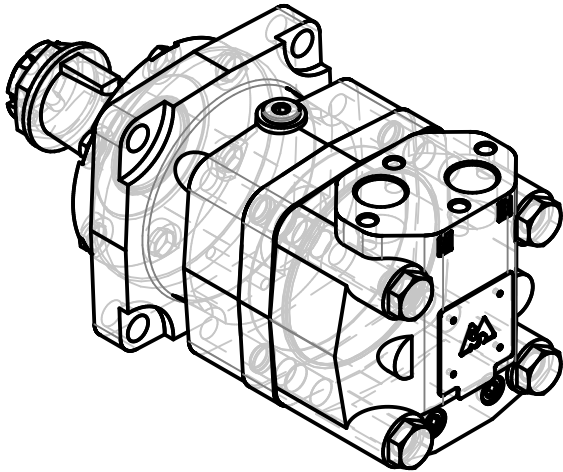

NOTE: Shown dimensions are in nominal, for maximal values see table.

NOTE: For additional dimensions and information about flange , shaft , endcover , etc. see next page.

L max	LS max
197.1	147.0

Confidential property of M+S Hydraulic, Bulgaria.
Please note that this drawing is automatically generated based on the selection. In case of possible changes or revisions in the drawing specifications, the selection process should be repeat. M+S is not responsible for any possible errors on the drawings.



MT200K

Design: M+S

Check:

Scale	Sheet	Rev.	Weight
Date 10.12.2025			21,5 [47.4]

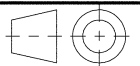

MT200K

FUNCTION DIAGRAMS

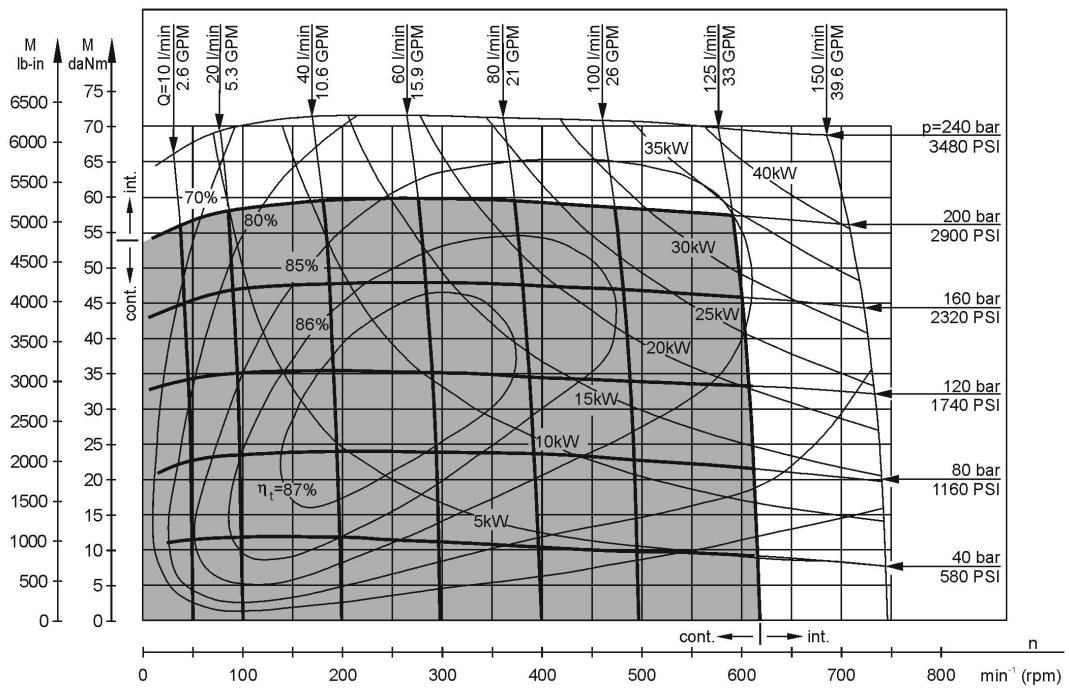

The function diagrams data is for average performance of randomly selected motors at back pressure 5±10 bar [72.5±145 PSI] and oil with viscosity of 32 mm²/s [150 SUS] at 50°C [122°F].

MT200K

DATA SHEET

Pressure Losses

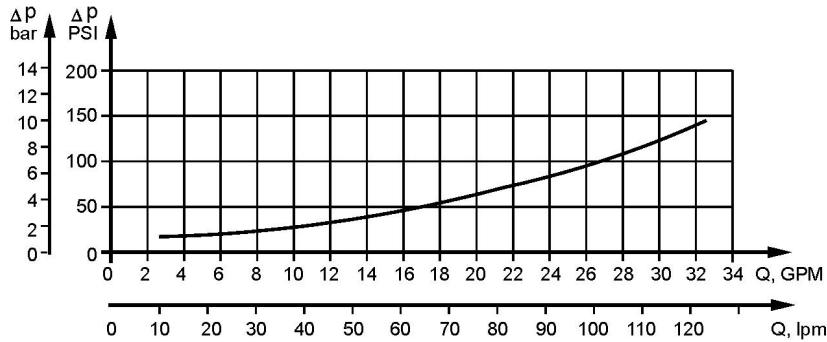

Oil flow in drain line

Pressure drop bar [PSI]	Viscosity mm ² /s [SUS]	Oil flow in drain line lpm [GPM]
140 [2030]	20 [98]	2,5 [.660]
	35 [164]	1,5 [.396]
210 [3045]	20 [98]	5 [1.321]
	35 [164]	3 [.793]

MAX: PERMISSIBLE SHAFT SEAL PRESSURE

Max. return pressure without drain line or max. pressure in the drain line

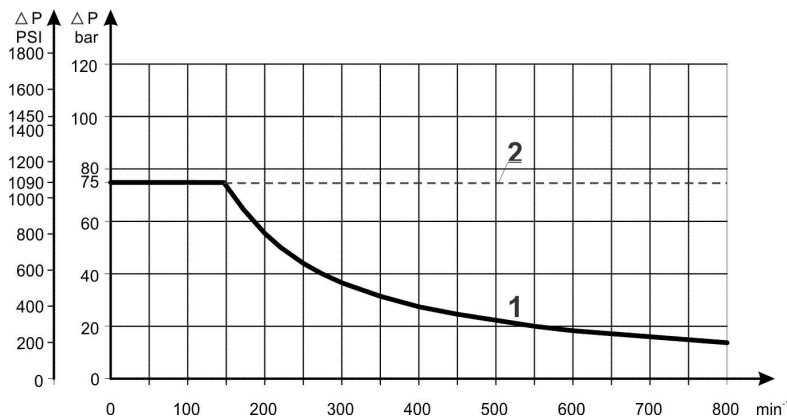

Curve "1" shows continuous operations.
Curve "2" shows intermittent operations.

PERMISSIBLE SHAFT LOAD

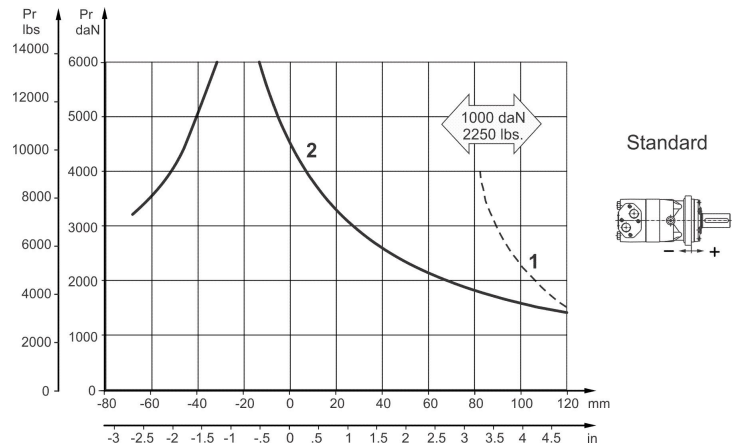

Curve "1" shows critical radial shaft load. The output shaft runs in tapered bearings that permit high axial and radial forces. The permissible radial load on the shaft is shown (curve 2) for an axial load of 0 N as function of the distance from the mounting flange to the point of load application. The curve 2 apply to a B10 bearing life of 2000 hours at 100 RPM.