

OIL TANK FIXING FLANGE

FTA - FTR



FT flanges make it possible to fix suction and return lines on the reservoir cover. Fitting a flexible insert allows separation of pipes. Both rigid pipes and flexible hoses can be separated from the reservoir walls, absorbing vibration and reducing plant noise emissions.

Temperature

- from -25° to +100°C

Compatibility

- NBR seals and Cork Gasket, compatible with: Mineral oils to ISO 2943 - aqueous emulsions Synthetic fluids, glycol water.

FTA

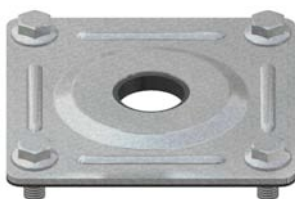

FTR

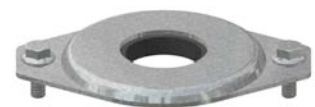

FTA - FTR (Materials)

- 1 - Flange: Galvanised steel
- 2 - Flange seal: Inorganic fibre
- 3 - Tube seal: NBR
- 4 - S screw: Galvanised steel

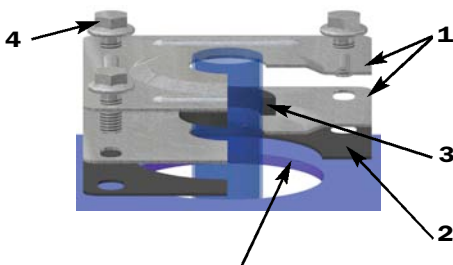

Drill the panel:

- Ø 105 for types from 1215 ÷ 3842
- Ø 145 for types from 4850 ÷ 8789

- 1 - Flexible element
- 2 - Seal

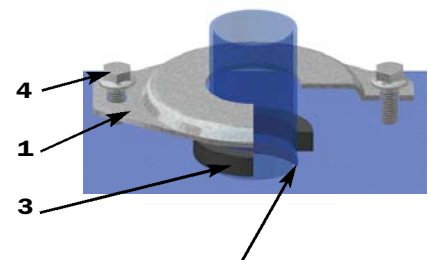

Drill the panel max 2 mm more than the pipe Ø

FTA

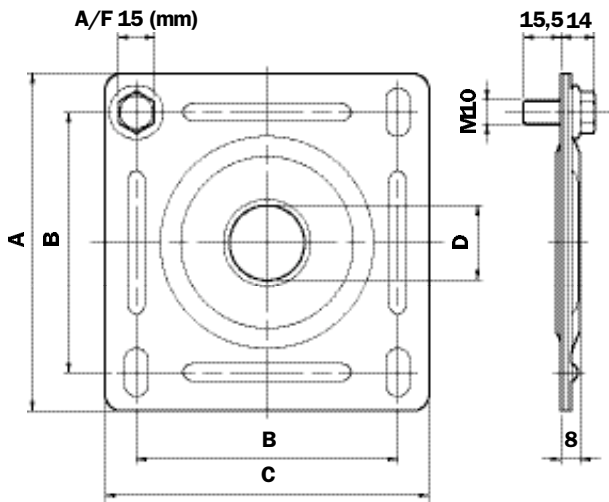

Type	A	B	C	Ø D	Weight (Kg)
FTA 1215	140	108	134	12÷15	0,590
FTA 1620	140	108	134	16÷20	0,570
FTA 2225	140	108	134	22÷25	0,550
FTA 2630	140	108	134	26÷30	0,530
FTA 3235	140	108	134	32÷35	0,500
FTA 3842	140	108	134	38÷42	0,520
FTA 4850	190	159	184	48÷50	0,920
FTA 6061	190	159	184	60÷61	0,900
FTA 7577	190	159	184	75÷77	0,860
FTA 8789	190	159	184	87÷89	0,830

N.B. Tightening torque MAX 20 Nm.

FTR

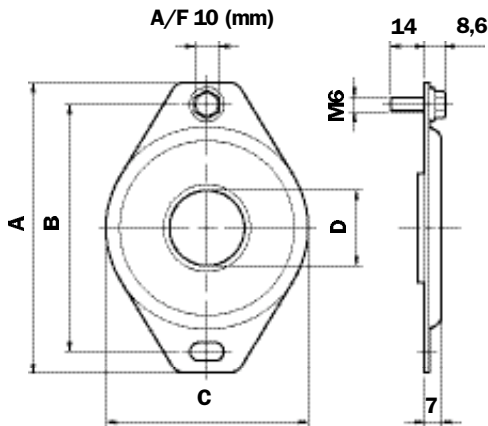

Type	A	B	C	Ø D	Weight (Kg)
FTR 0610	71	54	39,5	6÷10	0,045
FTR 1215	71	54	39,5	12÷15	0,043
FTR 1620	71	54	39,5	16÷20	0,040
FTR 2225	120	102	83,5	22÷25	0,100
FTR 2630	120	102	83,5	26÷30	0,103
FTR 3235	120	102	83,5	32÷35	0,098
FTR 3842	120	102	83,5	38÷42	0,095
FTR 4850	120	102	83,5	48÷50	0,090
FTR 6061	120	102	83,5	60÷61	0,085

N.B. Tightening torque MAX 20 Nm.

Suction line flange

FTA

Example: FTA

1 - Size

Ø Pipe Min - Max	Size
12 - 15	1215
16 - 20	1620
22 - 25	2225
26 - 30	2630
32 - 35	3235
38 - 42	3842
48 - 50	4850
60 - 61	6061
75 - 77	7577
87 - 89	8789

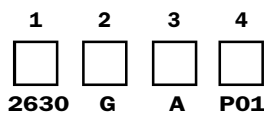

2 - Flange seal

G Inorganic fibre

3 - Pipe seal

A NBR

4 - Options

P01 MP Standard

Ordering information

Return line flange

FTR

Example: FTR

1 - Size

Ø Pipe Min - Max	Size
6 - 10	0610
12 - 15	1215
16 - 20	1620
22 - 25	2225
26 - 30	2630
32 - 35	3235
38 - 42	3842
48 - 50	4850
60 - 61	6061

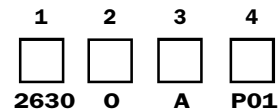

2 - Flange seal

O Without

3 - Pipe seal

A NBR

4 - Options

P01 MP Standard