

REVISION	ECN NUMBER	LOCATION	CHANGE DESCRIPTION
REVIZIJA	ŠT. OBL. O SPRE.	LOKACIJA	OPIS SPREMEMBE
01	77556		Z.R.

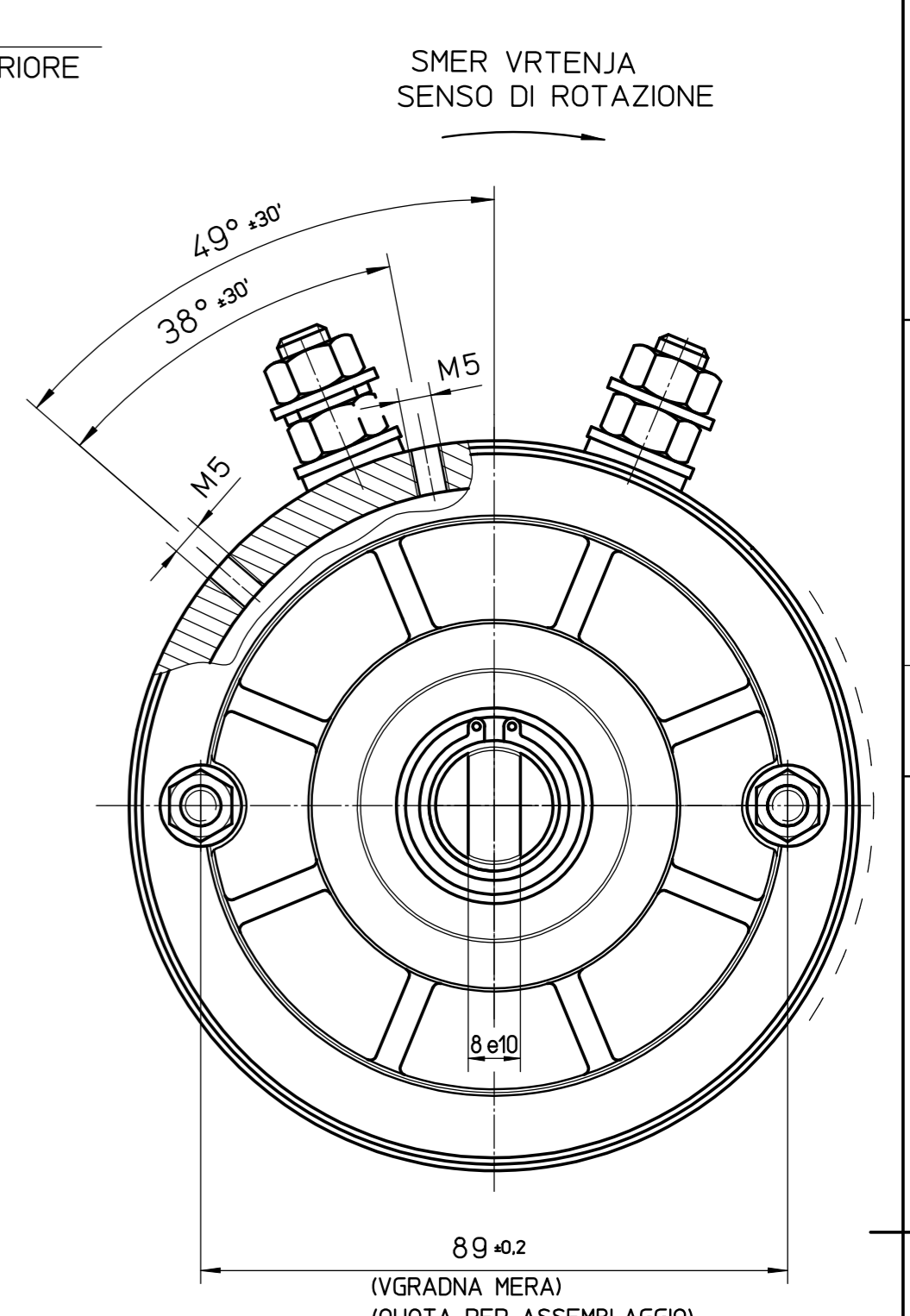

RAZPISNOVAJE TEGA DOKUMENTA, PREDAJAL UPORABNO ALI POSREDOVANJE VSEBINE IRETIM OSEBAM
 VSE PRAVICE PREGAZANE V POKREBU PODELITVE PATENTA ALI REGISTRACIJE MODELA.

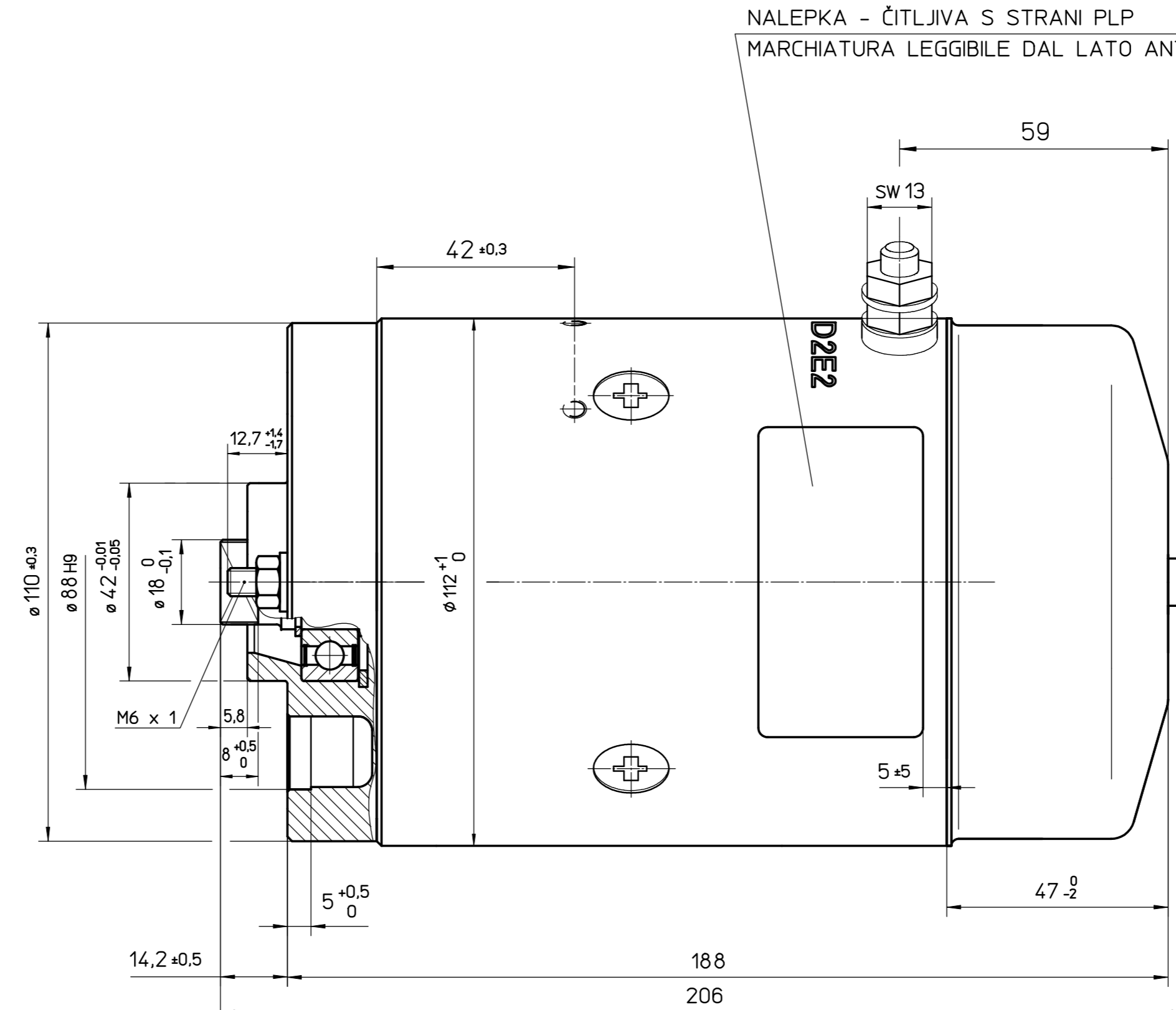
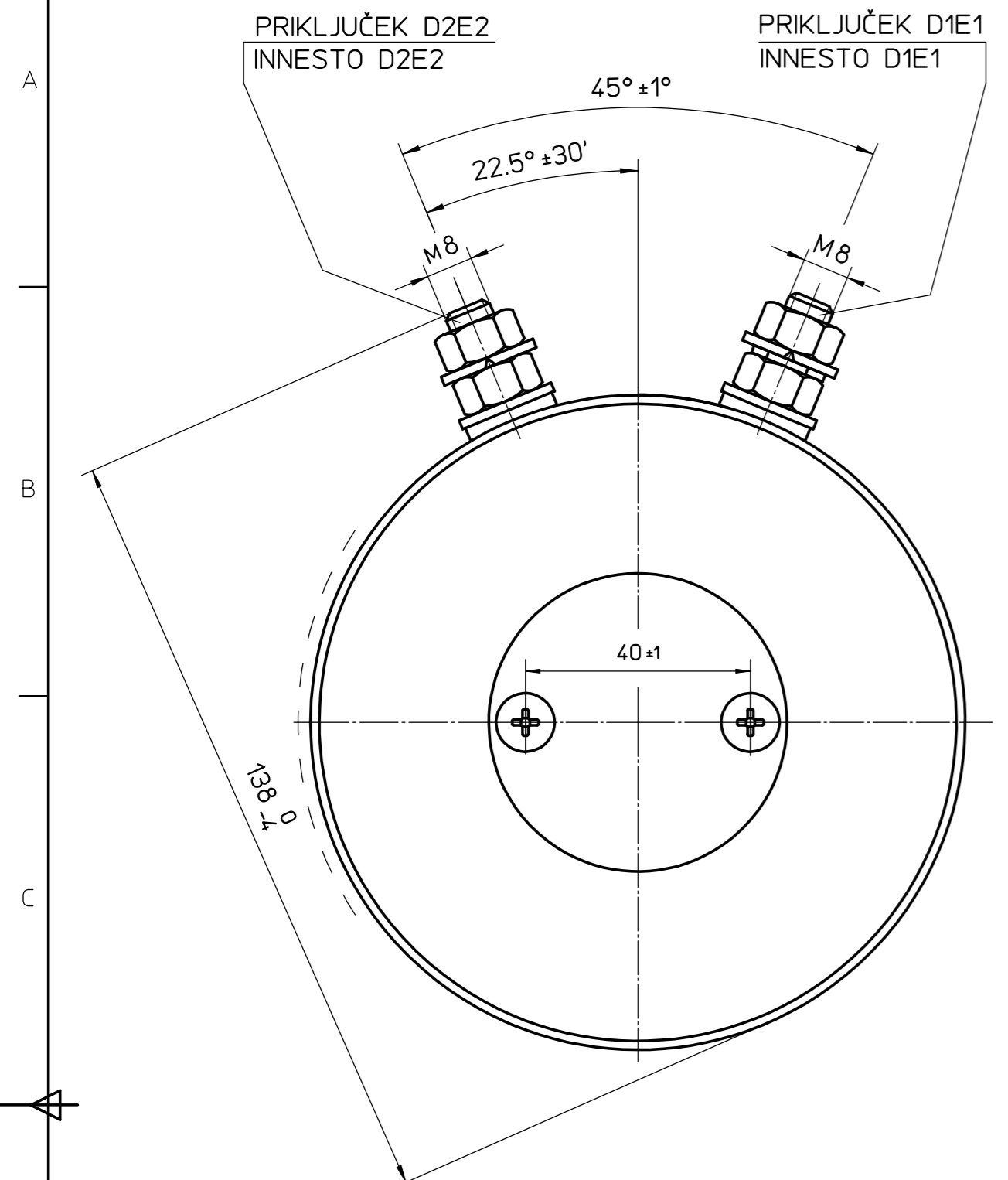
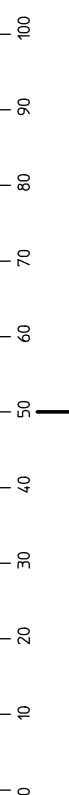

COPYING OF THIS DOCUMENT, AND GIVING IT TO OTHERS AND THE USE OR COMMUNICATION OF THE CONTENTS THEREOF, ARE FORBIDDEN
 UNLESS EXPRESSLY PERMITTED BY THE GRANTOR OF A PATENT OR REGISTRATION OF A UTILITY MODEL OR DESIGN.

KARAKTERISTIKA MOTORJA
Curve caratteristiche

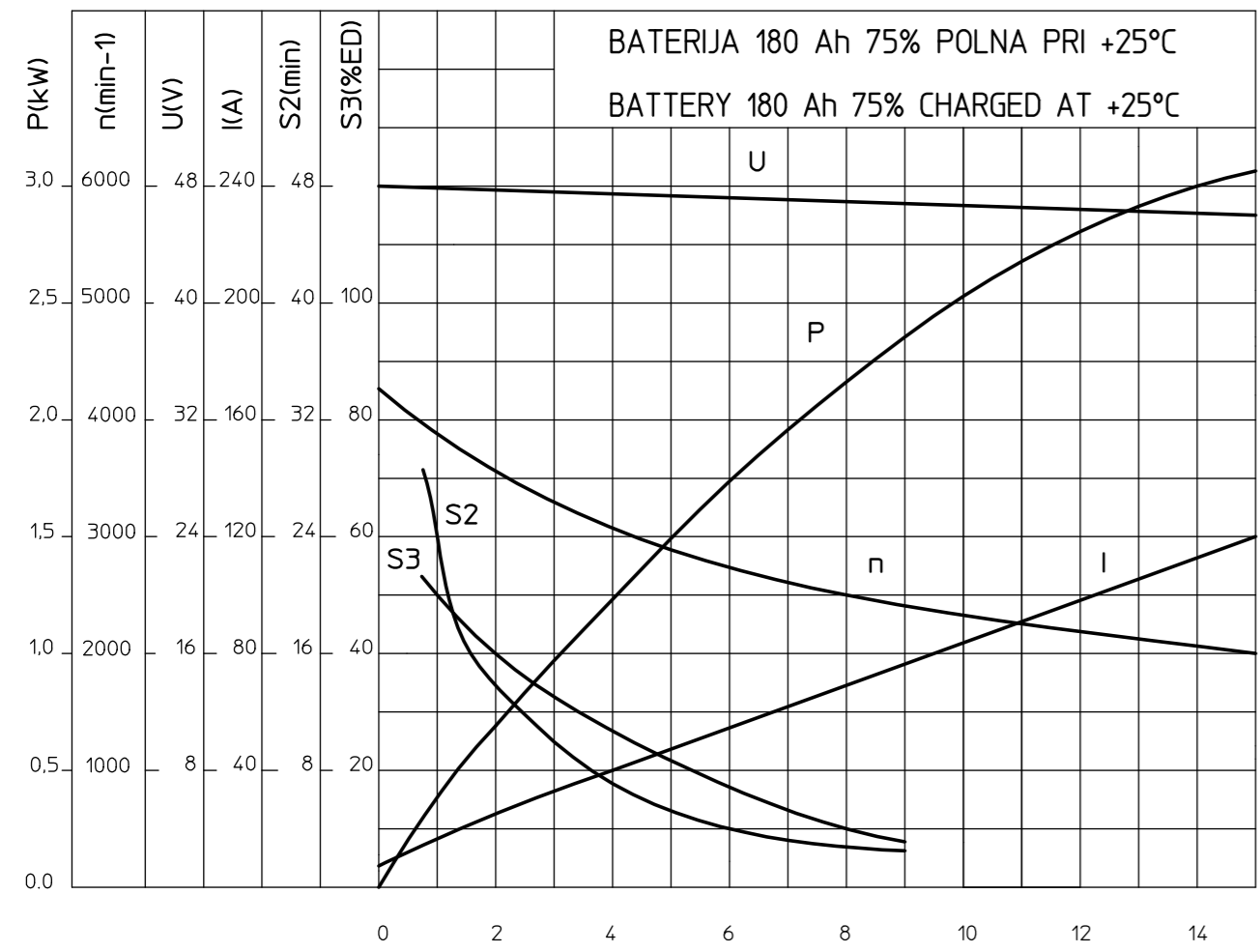

ODSTOPANJE OD KARAKTERISTIKE ± 5%
DEVIATIONE DELLA CARATTERISTICA ± 5%

TEHNIČNI PODATKI
Dati tecnici

NAPETOST TENSIONE	48 V
MOČ POTENZA	2.0 kW
HITROST VRTENJA VELOCITA DI ROTAZIONE	2500 min ⁻¹
SMER VRTENJA SENSO DI ROTAZIONE	DESNA DESTRA
NAČIN DELOVANJA REGIME DI FUNZIONAMENTO	S2 - 3 min S3 - 12% ED
STOPNJA ZAŠČITE GRADO DI PROTEZIONE	IP 54
IZVEDBA VERSIONE	IZOLIRANA MASA MASSA ISOLATA
MASA PESO	~ 7,3 kg
ZUNANJI IZGLED ASPETTO ESTERNO	CINKANO ZINCATO

VEZALNA SHEMA
Schema elettrica

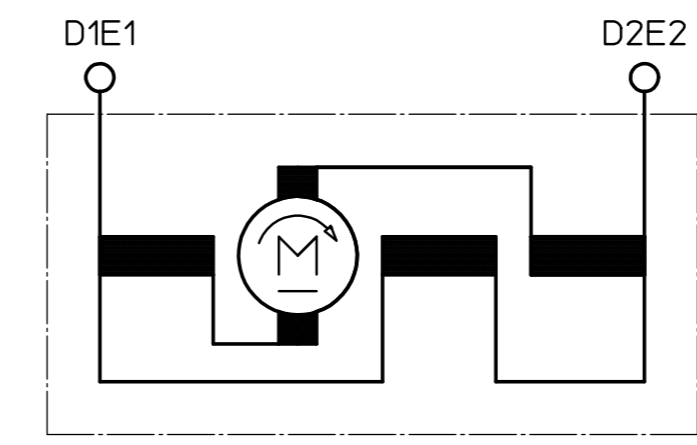

OPOMBE:

- MOTOR MORA USTREZATI QC 11.920.021 - TOČKA 9
- OZNAKE PRIKLJUČKOV PO PRIPOROČILIH IEC. PUBL. 34-8
- NETOLERIRANE MERE SO MAKSIMALNE.

Note:

- Motore corrisponde a QC 11.920.021 - punto 9
- Marchiatura dei contatti suggerite secondo raccomandazione IEC. PUBL. 34-8
- Le quote senza tolleranza sono massime.

NON. TOLE. DIM. / ODSTOP. NETOL. MER	EDGES UNDF. / NEDEF. ROBOVI	MATERIAL AND STANDARD / GRADIVO IN STANDARD	MASS / MASA
GDT	SURFACE PROTECTION / POVRŠINSKA ZAŠČITA	HEAT TREATMENT AND HARDNESS / TOPLOTNA OBDELAVA IN TRDOTA	- kg
ISO 1101	METRIC DATE / UG NX DATUM	NAME / IME	DOCUMENT TITLE / NAZIV DOKUMENTA
CREATOR / AVTOR	13.9.1994	Šinigoj	motor
DRAWN / KONSTRUIRAL	1.10.2018	Nejc Volk	AMJ 5133 48 V 2 kW
RELEASED / ODOBRILO	30.10.2018	Franc Barišek	motore
DESIGN CONTROL / KONTROLA KONSTR.	DC		DOCUMENT NUMBER / ŠTEVILKA DOKUMENTA
SCALE / MERILO			1:1
			STAGE / STOPNJA
			DOCUMENT TYPE / REVIZIJA
			PR 01
			MATERIAL NUMBER / ŠTEVILKA MATERIALA
			11.212.570
			SHEET (SHEETS) LIST (LISTOVI)
			1 (1)

ø88H9	+0,087
	0
8e10	-0,025
	-0,083

